

15 -ാം കേരള നിയമസഭ

2 -ാം സമ്മേളനം

നക്ഷത്ര ചിഹ്നം ഇല്ലാത്ത ചോദ്യം നം. 1764

29-07-2021 - ൽ മറുപടിയ്ക്ക്

കിഫ്ബി പദ്ധതിയിലെ റോഡ് പുനർനിർമ്മാണ മാനദണ്ഡങ്ങൾ

ചോദ്യം		ഉത്തരം	
ശ്രീ. മുഹമ്മദ് മുഹസിൻ		Shri K N Balagopal (ധനകാര്യ വകുപ്പ് മന്ത്രി)	
(എ)	കിഫ്ബി പദ്ധതിയിൽ ഉൾപ്പെടുത്തി റോഡുകൾ പുനർനിർമ്മിക്കുന്നതിന് അനുവർത്തിക്കുന്ന മാനദണ്ഡങ്ങൾ എന്തൊക്കെയാണെന്നു വിശദമാക്കാമോ;	(എ)	കിഫ്ബി റോഡ് പദ്ധതികളിൽ, MORTH മാനദണ്ഡങ്ങളെ ആധാരമാക്കി തയ്യാറാക്കിയതും, പൊതുവിൽ അനുവർത്തിക്കുന്നതുമായ, മാനദണ്ഡങ്ങൾ അനുബന്ധമായി ചേർക്കുന്നു.
(ബി)	ഇങ്ങനെ പുനർനിർമ്മിക്കുന്ന റോഡുകളിൽ ജല വിതരണത്തിനുള്ള പൈപ്പുകൾക്കും ടെലിഫോൺ കേബിളുകൾക്കും പ്രത്യേക സംവിധാനങ്ങൾ ഏർപ്പെടുത്തിയിട്ടുണ്ടോ;	(ബി)	കിഫ്ബി റോഡ് പദ്ധതികളിൽ ജലവിതരണത്തിനുള്ള പൈപ്പുകൾക്കും ടെലിഫോൺ കേബിളുകൾക്കും ആവശ്യകതയും സ്ഥലത്തിന്റെ ലഭ്യതയും അനുവദിച്ച ഫണ്ടിന്റെ പരിധിയും വിലയിരുത്തി സാധ്യമായ തരത്തിൽ യൂട്ടിലിറ്റി ഡക്സ് ഉൾപ്പെടെയുള്ള പ്രവൃത്തികൾ വിഭാവനം ചെയ്യാറുണ്ട്.
(സി)	റോഡ് നിർമ്മാണത്തിനായി അനുവർത്തിക്കുന്ന നിർമ്മാണ രീതി വിശദമാക്കാമോ?	(സി)	പൊതുവിൽ ഭൂരിഭാഗം റോഡുകളും ബി.എം, ബി.സി നിലവാരത്തിലുള്ളതാണ് വിഭാവനം ചെയ്ത് നടപ്പിലാക്കാറുള്ളത്. ഇതു കൂടാതെ FDR (എഫ് ഡെപ്ത് റിക്ലമേഷൻ) മുതലായ നൂതന സാങ്കേതിക രീതികളും അവലംബിക്കാൻ ശ്രമിക്കുന്നുണ്ട്.

സെക്ഷൻ ഓഫീസർ



Defining the Future

GUIDELINES FOR PLANNING AND DESIGN FOR ROADS & HIGHWAY PROJECTS FUNDED BY KIIFB

Version 2.0

20-November-2018

CONTENTS

CHAPTER - 1	4
KERALA PROFILE	4
1.1 ECONOMIC ACTIVITIES OF KERALA	5
1.2 LAND USE PATTERN OF KERALA	5
1.3 ROAD NETWORKS IN KERALA	6
1.4 VEHICLE GROWTH RATES IN KERALA	7
1.5 ROAD ACCIDENT RATE IN KERALA	8
1.6 POLLUTION	8
1.7 KERALA ROAD INFRASTRUCTURE	8
1.8 KIIFB FUNDED ROADS	9
CHAPTER – 2	10
COMPONENTS OF ROADWAY	10
2.1 RIGHT OF WAY (ROW)	10
2.2 CARRIAGEWAY	10
2.3 SHOULDERS	11
2.4 KERB	11
2.5 FOOTPATH	11
2.6 DRAINAGE	11
2.7 UTILITY DUCT	11
2.8 MEDIAN	12
2.9 CAMBER	12
2.10 ROAD FURNITURE	12
2.11 PROTECTION WORKS	12
2.12 CYCLE TRACK	12
2.13 STREET LIGHTING	13
CHAPTER – 3	14
STAGES IN PROJECT PREPARATION	14
3.1 PROJECT PREPARATION STAGES	14
3.2 SPECIFICATIONS	15
CHAPTER – 4	17
INVESTIGATION, SURVEY AND DEMAND ANALYSIS STUDY	17
4.1 INVESTIGATION PLANNING	17
4.2 RECONNAISSANCE SURVEY	18
4.3 PRELIMINARY SURVEY	18
4.4 DETAILED SURVEY	21

CHAPTER – 5	24
RIGHT OF WAY GUIDELINES	24
5.1 STATE HIGHWAYS: GUIDELINES	24
5.2 COASTAL HIGHWAY: GUIDELINES	26
5.3 HILL HIGHWAY: GUIDELINES	28
5.4 CITY ROADS: GUIDELINES	30
5.5 OTHER KIIFB ROADS: GEOMETRIC GUIDELINES	31
CHAPTER – 6	57
ROADWAY DESIGN	57
6.1 GEOMETRIC DESIGN AND ALIGNMENT PLANNING	57
6.2 DESIGN SPEED GUIDELINE	58
6.3 HORIZONTAL ALIGNMENT	59
6.4 VERTICAL ALIGNMENT	62
6.5 HILLY ROADS	66
CHAPTER – 7	69
PAVEMENT ENGINEERING DESIGN	69
7.1 GROUND IMPROVEMENT TECHNIQUES	69
7.2 PAVEMENT DESIGN	71
7.3 ALTERNATIVE PAVEMENT DESIGN	73
CHAPTER – 8	74
DRAINAGE SYSTEM	74
8.1 SIDE DRAIN SYSTEM	74
8.2 CROSS DRAIN SYSTEMS	76
CHAPTER – 9	78
UTILITY CORRIDOR AND CROSS DUCT	78
CHAPTER – 10	79
ROADSIDE AMENITY	79
10.1 FOOTPATH AND PEDESTRIAN CROSSING	79
10.2 BUS BAYS AND BUS SHELTERS	81
10.3 SMART STREET LIGHT	83
10.4 CYCLE TRACK	84
10.5 PARKING	85
10.6 AMENITY CENTRE	87
10.7 AVENUE PLANTATION AND LANDSCAPING	88

CHAPTER – 11	88
TRAFFIC FURNITURE	89
11.1 ROAD SIGNS	89
11.2 ROAD MARKING	101
11.3 ROAD STUDS	106
CHAPTER – 12	108
JUNCTION IMPROVEMENT	108
CHAPTER – 13	110
ROAD SAFETY BARRIERS	110
13.1 RAILINGS	110
13.2 RUMBLE STRIPS	111
13.3 SAFETY BARRIERS	111
13.4 GUARD POST	113
13.6 DELINEATORS	114
CHAPTER – 14	115
ROAD SAFETY AUDITING	115
14.1 ROAD SAFETY AUDITING	115
14.2 SOCIAL AUDITING	116
14.3 ENVIRONMENTAL AUDITING	117
CHAPTER – 15	118
SUSTAINABLE ROADS	118
15.1 IMPORTANCE OF SUSTAINABILITY IN PAVEMENT ENGINEERING	118
15.2 WHAT ARE THE BENEFITS OF BEING MORE SUSTAINABLE?	119
REFERENCES:	121

CHAPTER - 1

KERALA PROFILE

Kerala is a state in south India, and that spreads over 38,863 km² (15005 sq. mi) and is located at North latitude between 8° 18' and 12° 48' and East longitude between 74° 52' and 77° 22'. It is bordered by Karnataka to the North and North-East, Tamil Nadu to the East and South and Lakshadweep sea to the West.



Figure 1.1: Kerala map

Kerala state is a unique state in India has many advantages such as with 94% literacy rate, life expectancy of 74 years, highest human development index (HDI), high per capita income, availability of skilled manpower and highest sex ratio, four international Airports, 18 Sea ports including one International Container Transshipment Terminal and also It is State with second highest tele-density in India. Kerala is one of the prominent tourist destinations of India, with backwaters, hill stations, beaches and tropical greenery as its major attractions.

Kerala state is wedged between the Lakshadweep Sea and the Western Ghats. Kerala can be divided into three climatically distinct regions; the eastern highlands with mountainous terrain, the central midlands with rolling hills and the western low lands or coastal plains. The high lands slope down from the Western Ghats and the high lands, rise to an average height of 900m,

with several peaks over 1,800 m in height. The high land areas of major plantations like tea, coffee, rubber, cardamom and other species. The midland lies between the mountains and the low lands. It is made up of undulating hills and valleys. This is an area of intensive cultivation - cashew, coconut, areca nut, cassava, banana, rice, ginger, pepper, sugarcane and vegetables of different varieties are grown in this area. The 'Western Ghats' with their rich primaevial forests have a high degree of rainfall.

1.1 ECONOMIC ACTIVITIES OF KERALA

Kerala is the eighth largest economy in India. The important sectors of growth and investment in Kerala are IT & Electronics, Health Care Services, Tourism, Retailing, Plantations, Logistics, Education & Knowledge Sector, and Infrastructure. Service sector dominates in Kerala economy. Kerala is an established tourist destination for both Indians and non-Indians alike.

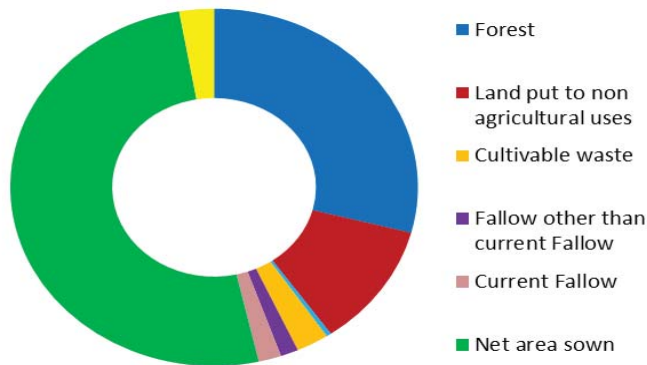

Figure 1.2: Kerala Tourism attractions

Kerala is well known for its beaches, backwaters, mountain ranges and wildlife sanctuaries. Foreign remittance augments the state's economic output by nearly 25 percent.

1.2 LAND USE PATTERN OF KERALA

Kerala state is unique in its Agro-climatic variations and cropping pattern as compared to other states in India. In the earlier days agricultural land utilization was according to the agronomic



Source: Directorate of Economics and Statistics, Kerala

Figure 1.3 : Kerala land use pattern

conditions of land and, food crops occupied a major part of the cultivated land. The cultivated area of the state is to around 67.6 per cent of the total geographical area. Within this, the Net Sown Area accounts for 52 per cent and, 16.83 per cent of the cultivated area is sown more than once. More than one-fourth of the area is under forest cover and 11.18 per cent of the area is put to non-agricultural use. On the other hand, there was a 4 per cent

increase in the area put to non-agricultural uses and a 7 per cent increase in the land under fallow.

1.3 ROAD NETWORKS IN KERALA

Transportation by road system is the only mode which could give maximum flexibility of service from origin to destination, to one and all. Road transport mode has the maximum flexibility for travel with reference to choosing of the route, direction, time and speed of travel. Road transportation is the only mode which caters for the movement of passengers and goods independently right from the place of origin up to the destination of any trip along the land. In other words, it is possible to provide door to door service only by road transport.

Table 1.1 Department wise road length in Kerala

Sl. NO	Name of Department	Length (km)	Percentage
1	Panchayats (LSGDs)	139380.410	67.81
2	PWD (R&B)	31812.096	15.48
3	Municipalities	18411.870	8.96
4	Corporations	6644.000	3.23
5	Forests	4575.770	2.23
6	Irrigation	2611.900	1.27
7	PWD (NH)	1781.570	0.87
8	Others (Railways, KSEB, harbour and irrigation)	328.000	0.16
	Total	205545.616	100

Source: Source: Economic review 2016, Kerala

Road density in the State is 853 km/100 sq.km and it is far ahead of the national average of 387 km/100 sq.km. The road density in Kerala is more than two times the national average and it reflects Kerala's unique settlement patterns.

1.4 VEHICLE GROWTH RATES IN KERALA

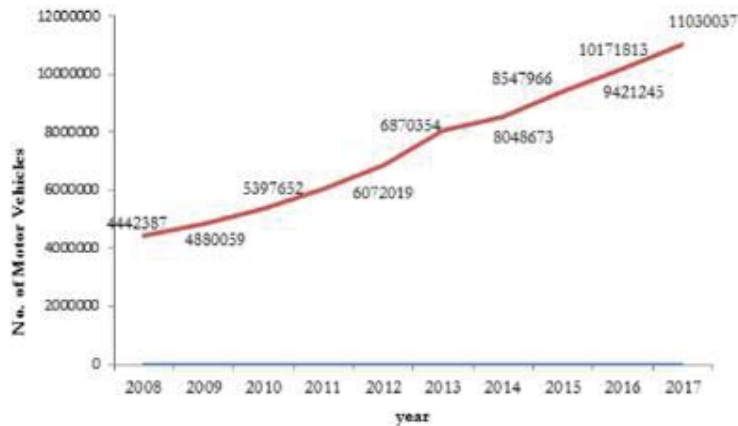

Figure 1.4 Kerala Vehicle growth rate, Source: Economic review 2017, Kerala

The growth of Motor Vehicles during the last ten years is shown in Figure 1.4. The number of vehicles per 1,000 population for Kerala in March 2017 was 330. According to World Development Indicators (2015), number of vehicles per 1,000 population in India was 18, for China it is 47, and for the United States, it is 507.

The growth of vehicle population in Kerala is eight per cent over the previous year. The number of motor vehicles having valid registrations as on March 31, 2017, is 11,030,037 as against 10,171,813 in the previous year.

About 2,574 vehicles are newly added to the vehicle population every day. Of this 1,802 are two-wheelers. The percentage of category-wise motor vehicles registered in 2016-17 is shown in Figure 1.5.

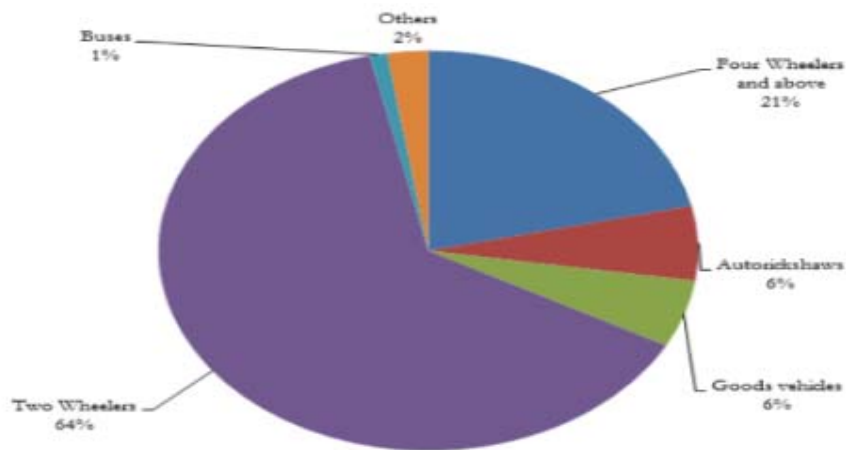

Figure 1.5: Vehicle composition in Kerala, Source: Economic review 2017, Kerala

1.5 ROAD ACCIDENT RATE IN KERALA

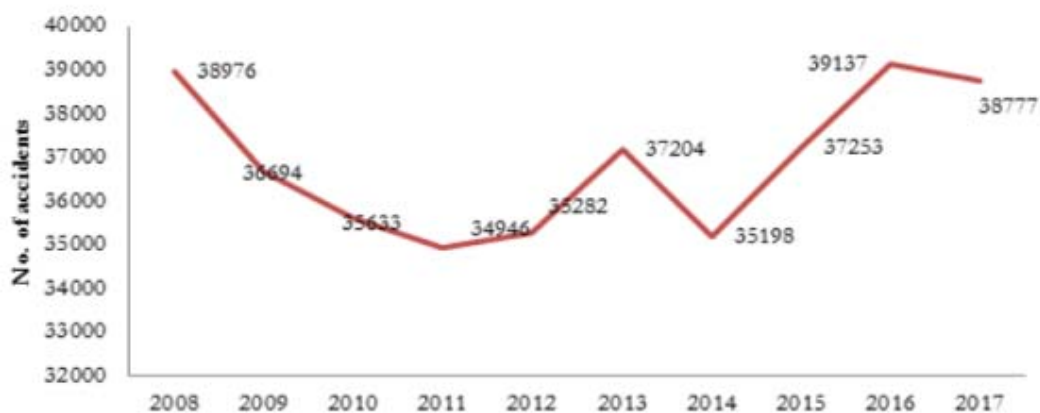

Figure 1.6 Accident rate in Kerala, Source: State Crime Records Bureau

Kerala recorded a total of 38,777 accidents in 2017; which is 351 accidents per lakh vehicles registered in the State.

1.6 POLLUTION

Rapid urbanization and growth of motor vehicles impose a serious effect on human life and its environment in recent years. The number of vehicles on the roads in Kerala has increased more than 20 times since 1975. Road transport is a major source of air pollution that harms human health and the environment. Vehicles emit a range of pollutants including nitrogen oxides (NOx) and particulate matter (PM). Traffic congestion increases vehicle emissions and degrades ambient air quality. Roads having less capacity and high volume of traffic leads to congestion which causes air pollution due to unwanted acceleration and deceleration.

The pollution due to traffic can't be reduced to zero because emission from fuel compression process can't control up to a limit. Pollution due to traffic can be reduced by providing high quality designed roads and sufficient capacity to roads.

1.7 KERALA ROAD INFRASTRUCTURE

Roads are maintained by various agencies in Kerala. These include National Highways, Public Works Department (Roads), Corporations, Municipalities, Panchayath, Irrigation, Forests, Railways, harbour and fisheries department, etc.

Road maintenance and construction are mainly funded by budget provisions, which are not enough to maintain a good infrastructure. Kerala government organised Kerala Infrastructure Investment Fund Board(KIIFB) to accelerate infrastructure development in the professional approach for ensuring sustainable growth in the economy. KIIFB will guide the Government for planning and sustained development of both physical and social infrastructure. The Fund established with the

main objective of providing investment for projects in the State of Kerala in sectors like Transport, Water, sanitation, Energy, Social & Commercial Infrastructure, IT and Telecommunication etc.

Large and sustainable transport sector is an economic driver and core to the development of the state

1.8 KIIFB FUNDED ROADS

Kerala Infrastructure Investment Fund Board (KIIFB) formed by the Kerala Government to provide high-quality infrastructure for developing Kerala. KIIFB shall undertake the funding of two main types of road/highway projects viz., new formation and up-gradation of existing road/highway projects which includes improvement/strengthening and/or widening works.

Among the above mentioned types of road/highway projects, the funding shall be restricted to the following categories of road/highway projects

- ❖ State Highways
- ❖ Coastal Highway
- ❖ Hill Highway
- ❖ City Roads (Arterial Roads)
- ❖ Other KIIFB Roads
- ❖ Bypass (to NH / SH / MDRs) / Ring road Projects

Chapter – 2

COMPONENTS OF ROADWAY

The main components of roadway are Right of way (RoW), Carriageway, Shoulders, Kerbs, Footpath, Drainage, Utility duct, Median, Road furniture, Protection works, Safety barriers and Cycle track. Components demand point by point arranging and are required to be adjusted to the nearby setting.

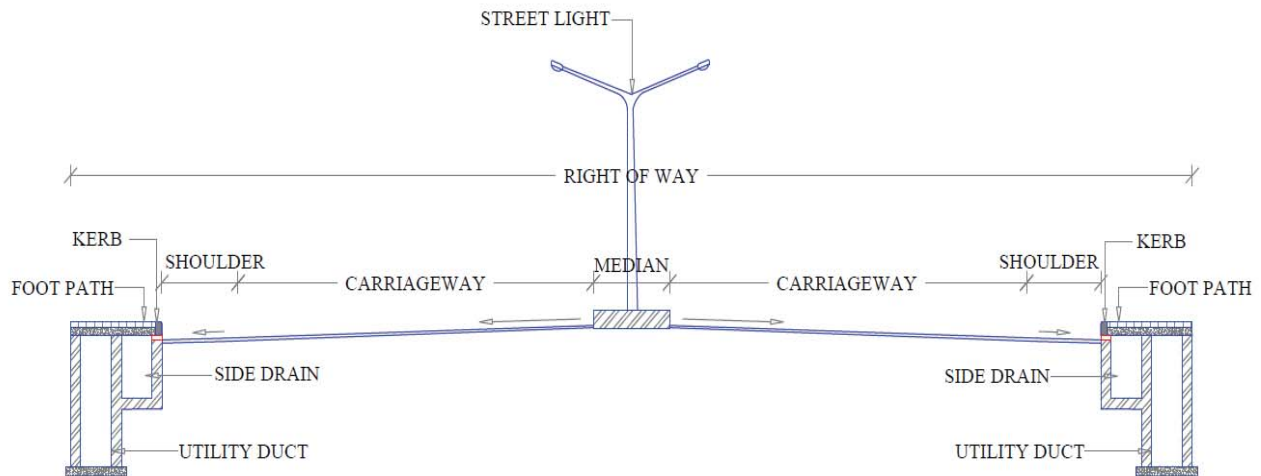

Figure 2.7 : Components of roadway for Divided Carriageways

2.1 RIGHT OF WAY (ROW)

The road land width or the Right-of-way width is the width of land secured and preserved in public interest for road development purposes. The right-of-way should be adequate to accommodate all the elements that make up the cross-section of the highway and may reasonably provide for future development

2.2 CARRIAGEWAY

A carriageway consists of a width of road on which a vehicle is not restricted by any physical barriers or separation to move laterally. Carriageway or the width of the pavement depends on the width of the traffic lane and number of lanes.

Minimum lane widths of 3.75m carriageway is provided in single lane road and a minimum of 3.5m lane width for each additional lane. Carriageway should be a dedicated space separated from slow-moving modes such as cycling, walkway etc. Carriageway should not be used for parking and laying utilities.

2.3 SHOULDERS

A shoulder is a portion of the roadway, contiguous with the travelled way and is intended for the accommodation of stopped vehicle, emergency use and lateral support of base and surface course.

The width of the shoulder should be adequate for giving workspace around a stopped vehicle.

2.4 KERB

A kerb (also termed as a curb) is a vertical or sloping member along the edge of pavement or shoulder, forming part of the gutter, strengthening or protecting the edge, and clearly defining the edge to vehicle operators.

Its functions are:

- To facilitate and control drainage
- To strengthen and protect the pavement edge
- To delineate the pavement edge
- To present a more finished appearance
- To assist in the orderly development of the roadside

2.5 FOOTPATH

To provide safe facility to pedestrians to walk along the roadway, footpaths or side-walks are provided in areas where the pedestrian traffic is noteworthy, and the vehicular traffic is also heavy. By providing a good footpath facility, the pedestrians can keep off from the carriageway and they are segregated from the moving vehicular traffic.

2.6 DRAINAGE

Road drainage is the process of removing and controlling excess surface and sub-soil water within the roadway or right of way. Adequate drainage is essential for the protection of the investment made in the road structures. It is important to provide an effective drainage system for all categories of roads in rural and urban areas to prevent early deterioration and failure of various components of a road including the road pavements.

2.7 UTILITY DUCT

A utility duct, utility tunnel, utility corridor, or utilidor is a passage built underground or above ground to carry utility lines such as electricity, water supply pipes, and sewer pipes, communications utilities like fibre optics, cable television, and telephone cables. It shall also be referred to as a services tunnel, services trench, services vault, or cable vault. Utility ducts avoid the periodic digging of pavement for utility laying or repairing.

2.8 MEDIAN

A central reserve or a median is the longitudinal space separating dual carriage-ways.

The functions of the median are:

- To separate the opposing streams of traffic
- To minimise headlight glare in case of wide medians
- To include space for safe operation of crossing and turning a vehicle at intersections at grade when turn pockets are provided.

2.9 CAMBER

Camber is also known as cross-slope and it, facilitates drainage of the pavement laterally. The pavement can have a crown or a high point in the middle with slopes downward towards the edge in case of single carriageway and uni-camber in case of dual carriageway.

The amount of camber to be provided depends upon the type of the material used in the surface and intensity of rainfall. Cross-slope for the shoulders should be generally steeper by 1% more than that of the carriageway.

2.10 ROAD FURNITURE

Road furniture represents a collection of elements intended to improve the road user's safety and driver's perception and comprehension of the continually changing appearance of the road. Road elements addressed include pedestrian and cycle facilities, traffic signs, road markings, marker posts, traffic signals, and lighting.

2.11 PROTECTION WORKS

Protection works are needed in areas susceptible to erosion such as, very steep slopes with easily erodible soils and rock strata. Erosion and soil disturbance can be avoided by using vegetation or appropriate engineering measures. Erosion often occurs on the cuts and embankments, as well as on the outlets of cross drains and at locations where, water flows on the surface of the road. Road protection works helps to avoid erosion and soil disturbance and protect the road structures.

2.12 CYCLE TRACK

Cycle tracks are provided in urban areas where the volume of cycle traffic on the road is very high. A minimum width of 2m is provided for the cycle track and the width may be increased by 1m for an additional cycle lane. The layout of the cycle tracks should be carefully decided in large highway intersections and traffic rotaries.

2.13 STREET LIGHTING

Street lighting is primarily intended to enable the road users (motorists, cyclists and pedestrians) to visualise the carriageway and the immediate surroundings in darkness. A large proportion of road accidents are caused in the night and one of the main reasons is, inadequate street lighting.

Chapter – 3

STAGES IN PROJECT PREPARATION

Road project preparation involves a chain of activities, such as, field survey and investigation, selection of alignment, carrying out various designs, preparation of drawings and estimates, etc. To be compatible with technical requirements and consistent with economy, it is essential that every project report is prepared after thorough investigations, collecting all relevant information and evaluating all possible alternatives.

3.1 PROJECT PREPARATION STAGES

The stages involved in the preparation and sanction of road projects are:

a) Pre-feasibility study

The pre-feasibility study is necessary to enable the funding agency to appreciate the features of the project. This is to be done based on the reconnaissance survey by collecting information based on the present status of the road and the anticipated traffic after development/improvement

b) Feasibility study /Preliminary project report preparation

The feasibility study is intended to establish whether the proposal is acceptable in terms of soundness of engineering design and expected economic benefits from the project for the investment involved.

c) Detailed engineering and plan of construction

Detailed engineering covers detailed alignment surveys, soil and materials surveys, pavement design studies, drainage studies, environmental management plan based on environmental impact assessment studies (if required), detailed drawings, estimates and implementation schedules and documents.

In some cases, especially for external funded and BOT projects, it may be necessary to prepare a pre-feasibility report to enable a funding agency or private financier to appreciate the broad features of the project, the levels of financial involvement and probable returns. On the basis of such work, Technical Approval and Financial Sanction (TA and FS) are accorded to the project.

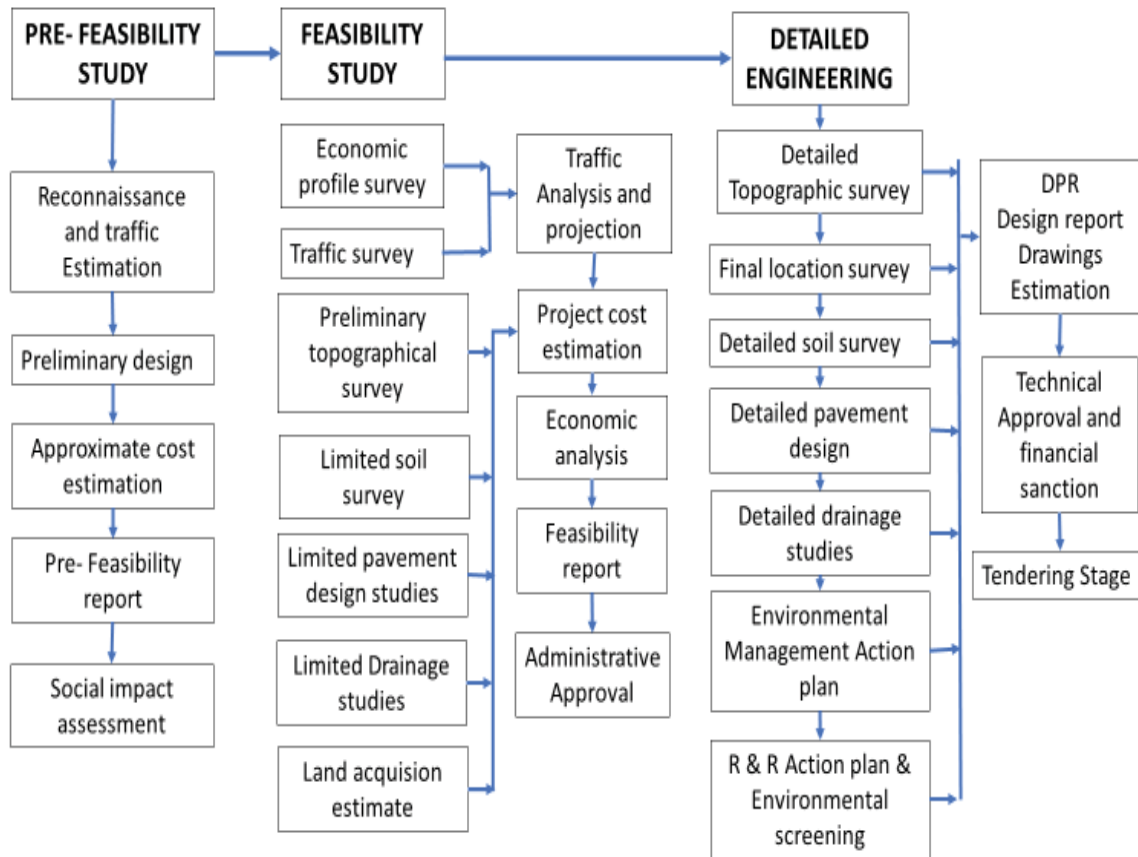

Figure 3.1 Project preparation stages, (Source IRC: SP:19-2001)

3.2 SPECIFICATIONS

The codes, standards and technical specifications applicable to the design of project components are:

- ❖ Indian Roads Congress (IRC) standards and specifications (Latest).
- ❖ Specifications for Road and Bridge Works, Ministry of Road Transport & Highways hereinafter referred to as MoRTH Specifications Fifth Revision, 2013.
- ❖ Any other standards referred to in the manual and any supplement issued with the bid document.
- ❖ The latest version of the codes, standards, specifications, etc. notified/published at least 60 days before the last date of bid submission shall be considered applicable.
- ❖ In the absence of any specific provision on any issue in the aforesaid codes or specifications read in conjunction with the specifications and standards contained in this Guidelines, the following standards shall apply in the order of priority:
 - (i) Bureau of Indian Standards (BIS).

- (ii) British Standards, Australian Standard, American Association of State Highway and Transportation Officials (AASHTO) Standards and American Society for Testing and Materials (ASTM) Standards, European Standards.
- (iii) Any other specifications/standards proposed by the concessionaire/contractor and concurred by the Technical Sanctioning Authority and KIIFB.
- (iv) The DPR should be prepared strictly as per IRC: SP:19-2001

Chapter – 4

INVESTIGATION, SURVEY AND DEMAND ANALYSIS STUDY

4.1 INVESTIGATION PLANNING

The road project may consist of either construction of a new road or improvements to an existing one. In either case, the working drawings must be prepared after detailed surveys, design and investigations. The manner in which surveys are conducted, has a vital influence on designs, on the production of quantities and cost estimates and finally on the execution of work. Thus, high responsibility rests upon those who organize the surveys and investigation.

Table 4.1 List of study reports that are required to be submitted along with DPRs

Type of reports	New formation	Improvement works
Classified traffic volume Count	-	Yes
Turning movement	-	Yes
Traffic survey for RoBs/Subways	-	Yes
Origin Destination Survey	Yes	Desirable
Speed and Delay studies	-	Yes
Axle load survey	Desirable	Desirable
Accident Records	-	Desirable
Hydrological studies	Yes	Yes
Pavement condition survey	-	Yes
Pavement evaluation	-	Yes
Soil Investigation	Yes	Yes
Pavement design	Yes	Yes
Strengthening/Rehabilitation Design	-	Yes
Topographic survey	Yes	Yes

The road surveys are classified according to their purpose into three general groups, namely Reconnaissance Survey, Preliminary Survey and Detail Survey.

4.2 RECONNAISSANCE SURVEY

Reconnaissance survey is done, to examine the general characteristics of the area for determining the most feasible route or routes for further detailed investigations. During the reconnaissance, the engineer visits the site and examines the general characteristics of the area before deciding the most feasible route for detailed studies. Only very simple instruments are used by the reconnaissance team to collect additional details rapidly. Some of the details to be collected during reconnaissance are given below;

- I. Valleys, ponds, lakes, marshy land, bridge, hills, permanent structure and other obstructions along the route
- II. Approximate values of the gradient, length of gradient and radius of curves of alternate alignments
- III. Number and type of cross drainage structures, maximum flood level and natural groundwater level along the probable routes.
- IV. Soil type along the route from field identification tests and observation of geological features.
- V. Source of construction material, water and location of stone quarries.

4.3 PRELIMINARY SURVEY

The preliminary survey is conducted for collecting all the physical information which affects the proposed route profile/or improvements of a road.

4.3.1 ROAD INVENTORY

Road inventory is conducted for collecting data by directly measuring the conditions of road.

Details required after road inventory are:

- (i) Existing Carriageway (ECW) and Right of way (RoW) of project corridors
- (ii) Photographs of the road shall be taken for showing existing road conditions as well as specific landmarks
- (iii) Terrain classification as per IRC:73 shall be followed:

Table 4.2 Terrain Classification

Terrain classification	Cross slope (%)
Plain	0-10
Rolling	10-25
Mountainous	25-60
Steep	Greater than 60

- (iv) Major/minor junctions passing through and Bridge inventory carried out with the recommendation of IRC: SP-52
- (v) Byroads with all physical details.
- (vi) Existing retaining structure details
- (vii) Existing Cross drain inventory shall be conducted as per IRC SP 19, to collect present conditions of the structure with reference of Tables 4.3 and 4.4

Table 4.3 Culvert Inventory Details

CULVERT						
Sl. No	Chainage	Type	Dimension	Direction of flow	Discharge conditions	Remarks

- (viii) Existing drainage details inventory shall be conducted to collect present conditions of the structure with reference of Tables

Table 4.4 Drainage inventory details

DRAINAGE						
Rt/Lt	Chainage	Type	Dimension	Condition	Discharge point	Remarks

- (ix) Suggestions, location identification for bus bay improvements/shifting.
- (x) Off-street parking spaces for trucks, taxis and auto rickshaws.
- (xi) Identification of locations for overtaking zone.
- (xii) Land availability at curves for extra widening.

4.3.2 TRAFFIC SURVEY

The traffic engineering studies carried out for collecting traffic data are also called traffic survey. Traffic engineering studies are carried out to analyse the traffic characteristics and their movement along the identified roads. The results of these studies are used for the design of geometric features and traffic control measures for safe and efficient traffic movement. The analysis of results of these studies are also useful for assessing the need of the proposed road project with justifications.

The different traffic engineering studies generally carried out are:

(i) Traffic volume studies

Traffic volume or traffic flow is expressed as the number of classified vehicles that pass across a given transverse line of the road during a unit time. Traffic volume is generally expressed as number of vehicles per hour or per day, per lane. It is also expressed in passenger car units(PCU) per hour using the appropriate PCU factors as per relevant IRC. The following aspects should be considered in traffic volumes studies in road projects.

- 1) Traffic volume count to be conducted for a minimum of three consecutive days that may include working day and market day.
- 2) The count stations should be such that the results represent the traffic flow of a homogenous section of the road.
- 3) Classified traffic volume count is carried out as per IRC: SP:19-2001 and the design traffic estimated as per Clause 4.6 of IRC:37-2012 or as per IRC: SP:72-2015, depending on the volume of traffic.
- 4) Traffic survey for the design of road junction/at-grade intersections shall conform to IRC: SP-41.
- 5) Traffic growth rate for the traffic projection shall be followed as per IRC: 108.
- 6) In case of low volume roads, the relevant IRC viz., IRC: SP:72-2015 may be referred for the design of the pavement thickness.

(ii) Spot speed studies

Speed is an important transportation consideration because it relates to safety, time, comfort, convenience, and economics. Spot speed studies are used to determine the speed distribution of a traffic stream at a specific location. The data gathered in spot speed studies are used to determine vehicle speed percentiles, which are useful in making many speed-related decisions. Spot speed data have several safety applications.

(iii) Speed and delay studies

The speed and delay studies are useful in identifying the locations of congestion, the causes and in arriving at suitable improvement measures to reduce the delays or increase the travel speed.

(iv) Origin and destination (O-D) studies

O-D studies are essential for either comprehensive planning of new road network or for improvements in the existing road network. The O-D data are also useful for planning and design of expressways, bypasses around congested towns and cities, location for truck lay-byes/rest areas, etc.

(v) Parking studies

Parking studies are conducted for the planning and design of suitable parking facilities that are suitable to meet the demand keeping in view the available space for the parking facility.

(vi) Accident studies

Systematic accident studies shall be carried out by investigating the causes of accidents and hence take preventive measures in terms of design and control.

(vii) Pedestrian studies

For planning and design of pedestrian facilities, safety features like pedestrian behaviour and numbers shall be studied.

4.3.3 PAVEMENT CONDITION SURVEY

Pavement Condition Surveys refer to activities performed to give an indication of the serviceability and physical conditions of the pavements. Data collection is accomplished by visually estimating distresses present within each roadway section. Should be carried out as per the performa suggested in IRC:82

Table 4.5 Criteria for Classification of Pavement Sections

Classification of road	Pavement condition
Good	No cracking, rutting less than 10mm
Fair	No cracking or cracking confined to single crack in the wheel track with rutting between 10mm and 20mm
Poor	Extensive cracking and/or rutting greater than 20 mm. Sections with cracking exceeding

4.4 DETAILED SURVEY

A detailed survey shall be conducted to collect necessary information for road design and preparation of detailed working drawings.

4.4.1 TOPOGRAPHIC SURVEYS

Detailed topographic survey of bridge crossings, streamlines, towns, villages, road edges, road boundaries, cuts, ditch edges, culverts, hilltops, water crossings, embankments, etc. shall be taken. The data shall be used to generate a Digital Terrain Model (DTM) for the whole road.

Topographic surveys are conducted preferably using LIDAR and the data is used to plot the Longitudinal Section and Cross Section. The finished road level and the subgrade level shall be decided as suggested in IRC:34-2011.

4.4.2 SOIL INVESTIGATION

The properties of soil at subgrade level is required for road construction works. The common soil test for road construction includes classification of soil, particle size distribution, moisture content determination, specific gravity, liquid limit and plastic limit tests.

1. The Subgrade soil is to be tested for its properties @ 1 trial pit/km and as per IRC:37-2012, if the length of the road is more than 10km.
2. For shorter length of roads, a minimum of 2 trial pit/km shall be staggered and taken. All basic tests viz., Atterberg's limits, Proctor density (IS:2720- Part-8), OMC, Soaked CBR at max dry density and OMC, free Swell Index along with Wet sieve analysis results shall be conducted and form part of the DPR.
3. Where ever required, effective CBR shall be determined as per IRC:37-2012 Clause 5.2.
4. Detailed investigation of landslides may be done compulsorily in Hill highways. Reference may be made from IRC SP:15
5. For designing culverts and minor bridge, the soil investigation for bearing capacity of soil and scour depth in addition to common soil tests are to be conducted.

4.4.3 AXLE LOAD SURVEY

Axle load survey is carried out to determine the Equivalent Wheel Load Factor (EWLF) values or Vehicle Damage Factor (VDF) values of heavy commercial vehicles which affects the design of flexible pavement structure as per the specified sample size as per IRC:37-2012.

1. One-day axle load survey shall be conducted, for road improvement projects, as per IRC:37-2012 / IRC: SP:19.
2. For all roads that are expected to carry design traffic more than 5 msa, axle load survey shall mandatorily be conducted.
3. For low volume roads, indicative VDF values as per IRC:37-2012 may be considered.

4.4.4 HYDROLOGICAL STUDIES

The function of the drain is to drain surface and subsurface water away from the roadway, Before the design of drainage and cross drain structures. the amount of runoff from the road surface shall be estimated. For better performance and long life, the drainage design shall be followed as per the standards.

- (i) Natural drains and conditions shall be considered for proper drainage, as well as economical design.
- (ii) If the newly constructed drain length is more than 75% length of road, a proper hydrological study shall be conducted for validation of drain use.
- (iii) Type of hydrological studies includes
 - Rainfall analysis
 - Runoff analysis
 - Contour studies

4.4.5 PAVEMENT EVALUATION STUDIES

Strengthening of existing pavements shall be designed based on the procedure outlined in IRC: 81, using Benkelman beam deflection studies and analysis or by adopting Falling Weight Deflectometer as per IRC:115.

The characteristic deflection of road stretches shall be found out using BBD/FWD survey and analysis with necessary corrections for temperature, subgrade moisture content and seasonal corrections. Along with pavement evaluation studies, core test of existing pavement should be tested to check type and thickness of pavement layers. Based on the extent and severity of distresses, the possibilities of recycling of the pavement layers can be assessed.

Chapter – 5

RIGHT OF WAY GUIDELINES

5.1 STATE HIGHWAYS: GUIDELINES

State Highways are arterial roads connecting district headquarters and important towns within the state and connecting national highways or highways of the neighbouring state.



Table 5.1 Right of way guideline for State highway

Terrain	Plain and Rolling Terrain			Hilly Terrain		
	>30000	30000-18000	<18000	>12000	12000-9000	< 9000
Stretch PCU/ Day	>30000	30000-18000	<18000	>12000	12000-9000	< 9000
Carriageway (m)	2 x 7	2 x 5.5	7	2 x 7	2 x 5.5	7
Hard Shoulders (m)	2 x 1.5	2 x 1.5	2 x 1.5	2 x 1.5	2 x 1.5	2 x 1.5
Footpath (m)	2 x 2	2 x 2	2 x 1.8	2 x 1.5	2 x 1.5	2 x 1.5
Drain	Under foot-path	Under foot-path	Under foot-path	Under foot-path	Under foot-path	Under foot-path
Utility	Under footpath					
Median (m)	2	0.5	-	2	0.5	-
Avenue plantation	If land available					
ROW (m)	23	18.5	13.6	22	17.5	13
Figure	5.19& 5.20	5.15& 5.16	5.9 & 5.10	5.17 & 5.18	5.13 & 5.14	5.7 & 5.8

- When locations where land constraints prevail, a limiting value of 1.5 m wide walkway can be adopted
- Footpaths are mandatory at thickly populated locations in village and town limits and at locations with educational institutions, hospitals, Government offices and other public amenities.

- c) Based on the importance of road and specific nature of any particular road, case by case variations may be adopted and shall be pre-approved by KIIFB during concept design stage.
- d) Guidelines are given for minimum requirement of Right of Way and the features to be provided. The required RoW may be adopted based on the terrain of land wherever side slopes, retaining wall etc needs to be provided. The cross-sectional parameters shall be retained as per the minimum specifications provided in the table above.

5.2 COASTAL HIGHWAY: GUIDELINES



The Kerala coast is 590 km long, laying in the direction of North-Northwest to South-Southeast, with many special features like sea cliff formed by the action of waves on the coast. Distributed on the coast, there are long patches of sandy beaches. The coast acts as major resource for coastal tourism development in the state. Nine out of fourteen districts of Kerala have coastline.

There are nearly 200 village panchayats, 11 municipalities and four corporations located along the coast facing the sea, or backwaters and about 30% of the population of Kerala live in the coastal zone. The Kerala coastal area is the centre for many economic activities like agriculture, aquaculture, fishing, fish processing industry, chemical industry, mining and tourism. Beaches and backwaters are the major attraction of the tourists in this area.



Coastal highway is one of the biggest infrastructure projects by Kerala government. It will make transportation access easier for vehicles passing through the state's coast. Coastal highway will begin at Poovar in Thiruvananthapuram district and end at Kunjathoor in Kasarakode district by passing through 9 districts. The coastal highway will ensure easy connectivity to ports such as Vallarpadam, Vizhinjam and Kollam. Easy cargo movement and fisheries development are the stated aims of the project.

Table 5.2 Right of way guidelines for Kerala coastal highway

Road type	CH 1	CH 2
Carriageway(m)	7	7
Hard Shoulders(m)	2 x 1.5	2 x 1.5
Footpath(m)	2 x 1.8	2 x 1.8
Drain	Under footpath	Under footpath
Utility	Under footpath	Under footpath
Cycle track(m)	2*	-
ROW (m)	15.6	13.6
Figure	5.11 & 5.12	5.9 & 5.10

*Cycle track to be provided for a minimum of atleast 3 km continuously in coastal highway stretches.

- a) Footpaths are mandatory at thickly populated locations in village and town limits and at locations with educational institutions, hospitals, Government offices and other public amenities.

5.3 HILL HIGHWAY: GUIDELINES

The mountain ranges in Kerala consisting of the highland area of the Western Ghats, exude an exotic charm. The hill highway rise to an average height of 1520 m, The tropical forests



of the Ghats, house rich and unique flora and fauna. Kerala has many destinations known for their natural beauty and exquisite landscape. Expansive plantations of tea, coffee, rubber and fragrant cardamom and other spices for which Kerala is famous for, are cultivated on the slopes of these hill stations.

The Hill Highway or Malayora Highway is the longest state highway in Kerala. The proposed highway extends from Parassala in Thiruvananthapuram District to Nandarapadavu in Kasaragod district



This highway will pass through 13 out of the 14 districts of Kerala state. With the development of the proposed hill highway, distance from many production centres in the hilly regions to market and commercial centres of the state gets reduced.

The proposed hill highway will not only provide a quick access to hilly regions, but also, can act as a catalyst to overall socio-economic development.

Table 5.3 Right of Way guide line for Kerala Hill Highway

Roadway components	Width
Carriageway (m)	7
Hard Shoulders (m)	2 x 1.5
Footpath (m)	2 x 1.8
Drain	Under footpath
Utility	Under footpath
ROW (m)	13.6
Figure	5.9 & 5.10

- a) Concrete / Paver block shoulders can be provided in such cases where the required camber and drain condition are available.
- b) Footpaths are mandatory at thickly populated locations in village and town limits and at locations with educational institutions, hospitals, Government offices and other public amenities.

5.4 CITY ROADS: GUIDELINES

City roads or arterial roads are provided to enable intra-urban travels such as travel to central business district and outler residential areas or between suburban centres. Parking, loading and unloading activities are usually restricted and regulated in city roads. Pedestrians can cross only at intersection / designated pedestrian crossings.



Table 5.5 Right of way guidelines for city roads,m

Type of road	City Road (CR) 1	City Road (CR) 3
Carriageway (m)	2 x 5.5	5.5
Hard Shoulders (m)	2 x 0.5	2 x 0.5
Footpath (m)	2 x 2.5	2 x 2
Shy of way (m)	2 x 0.25	-
Drain	Under foot-path	Under foot-path
Utility	Under footpath	Under footpath
Median (m)	0.5	-
Cycle track (m)	3	-
Avenue plantation (m)	(2 x 1.5) *	(2 x 0.75) *
ROW (m)	24	12
Figure	5.21 & 5.22	5.5 & 5.6

* Avenue plantation shall be provided based on land availability

5.5 OTHER KIIFB ROADS: GEOMETRIC GUIDELINES

The classification of roads enables the road designer to relate the geometric and structural design standards of the roads. For planners, this provides a basis for long-term planning, where different priorities can be assigned to different categories.

Table 5.6 Right of way guidelines for other KIIFB roads

Terrain	Plain and Rolling Terrain					Hilly Terrain			
	>30000	30000-18000	18000-8000	8000-5000	<5000	>12000	12000-7000	7000-4000	<4000
Stretch PCU/Day	>30000	30000-18000	18000-8000	8000-5000	<5000	>12000	12000-7000	7000-4000	<4000
Carriageway (m)	2 x 7	2 x 5.5	7	7	5.5	2 x 7	2 x 5.5	7	5.5
Hard Shoulders(m)	2 x 1.5	2 x 1.5	2 x 1.5	2 x 1	2x 0.75	2 x 1.5	2 x 1.5	2 x 1.5	2 x 0.75
Footpath in urban areas(m)	2 x 2	2 x 2	2 x 1.8	2 x 1.5	2 x 1.5	2 x 1.5	2 x 1.5	2 x 1.5	2 x 1.5
Drain	Under foot-path	Under foot-path	Under foot-path	Under foot-path	Under foot-path	Under foot-path	*Under foot-path	*Under foot-path	*Under foot-path
Utility	Under footpath								
Median, min(m)	2	0.5	-	-		2	0.5	-	-
Avenue plantation(m)	(2 x 2) *	(2 x 1) *	If land available			(2 x 2) *	(2 x 1) *	If land available	
ROW(m)	23	18.5	13.6	12	10	22	17.5	13	10
Figures	5.19& 5.20	5.15& 5.16	5.9& 5.10	5.3 & 5.4	5.1 & 5.2	5.17 & 5.18	5.13 & 5.14	5.7 & 5.8	5.1 & 5.2

* Avenue plantation should be provided in Bypass/Ring roads

- a) Based on the importance of roads and specific nature of any particular road, case by case variations may be adopted and shall be pre-approved by KIIFB during concept design stage.

- b) Guidelines are given for minimum requirement of Right of Way and features to be provided. The required RoW may be adopted based on the terrain of land wherever side slopes, retaining wall etc needs to be provided. The cross-sectional parameters shall be retained as per the minimum specifications provided in the table above.
- c) Concrete / Paver block shoulders can be provided in such cases where the required camber and drain condition are available.
- d) Footpaths are mandatory at thickly populated locations in village and town limits and at locations with educational institutions, hospitals, Government offices and other public amenities.

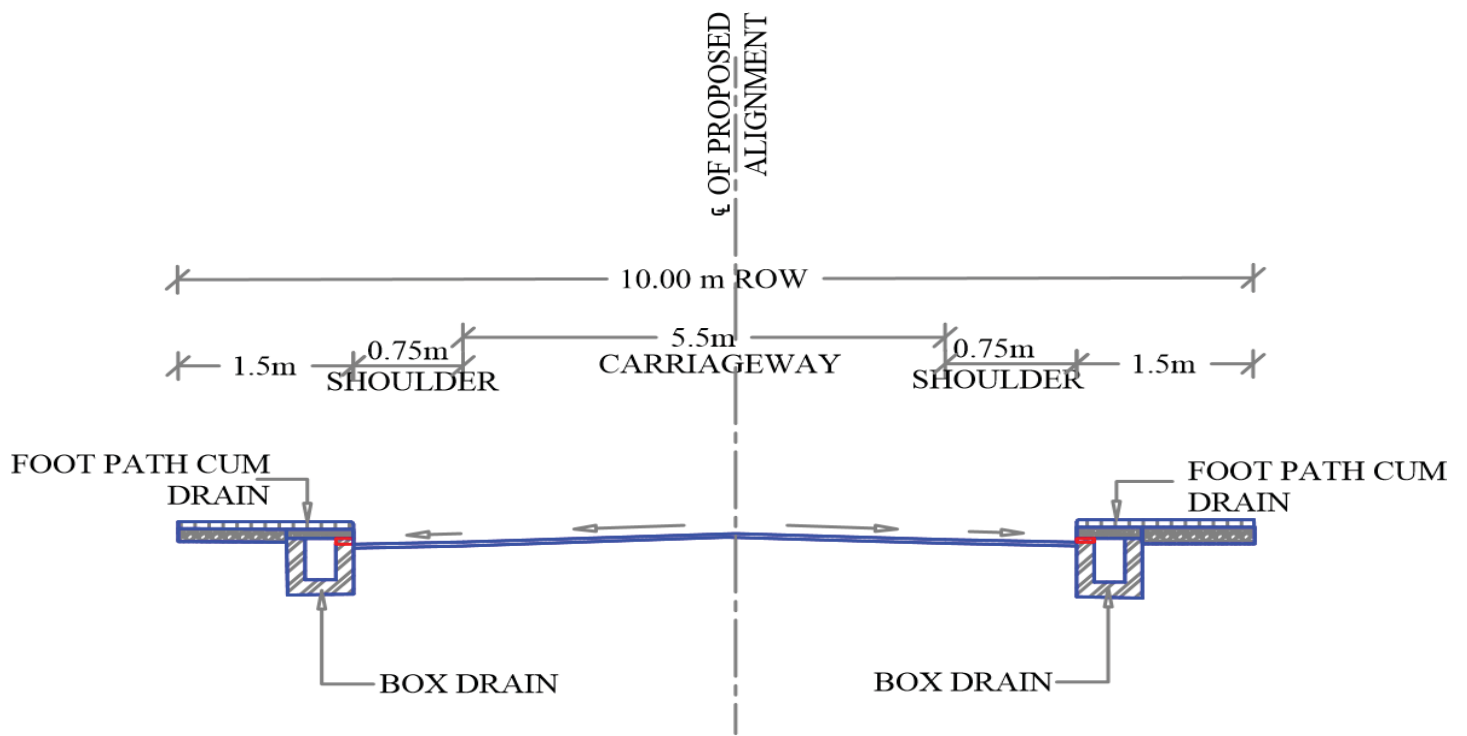

Figure 5.1 Typical cross section of 10m Right of way

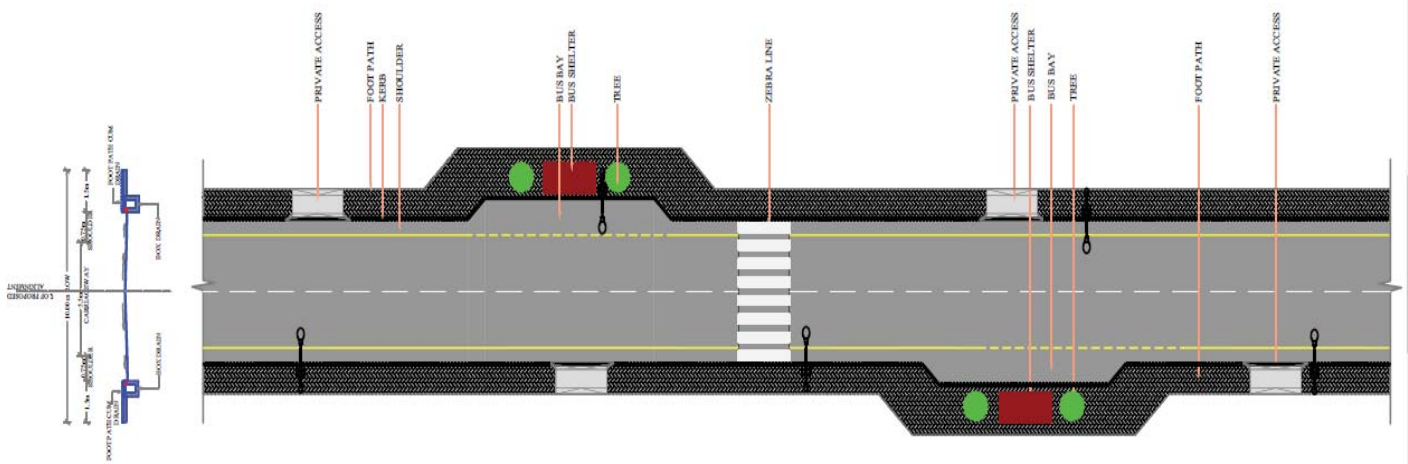

Figure 5.2 Typical layout of 10m Right of way

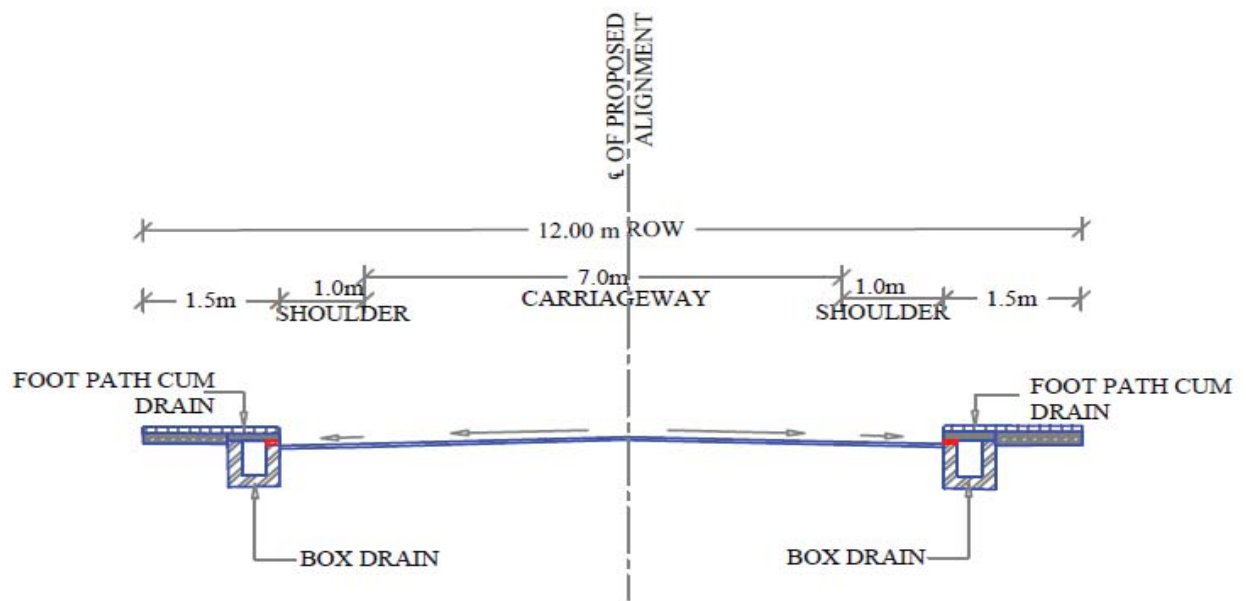

Figure 5.3 Typical cross section of 12m Right of way with 7m carriageway

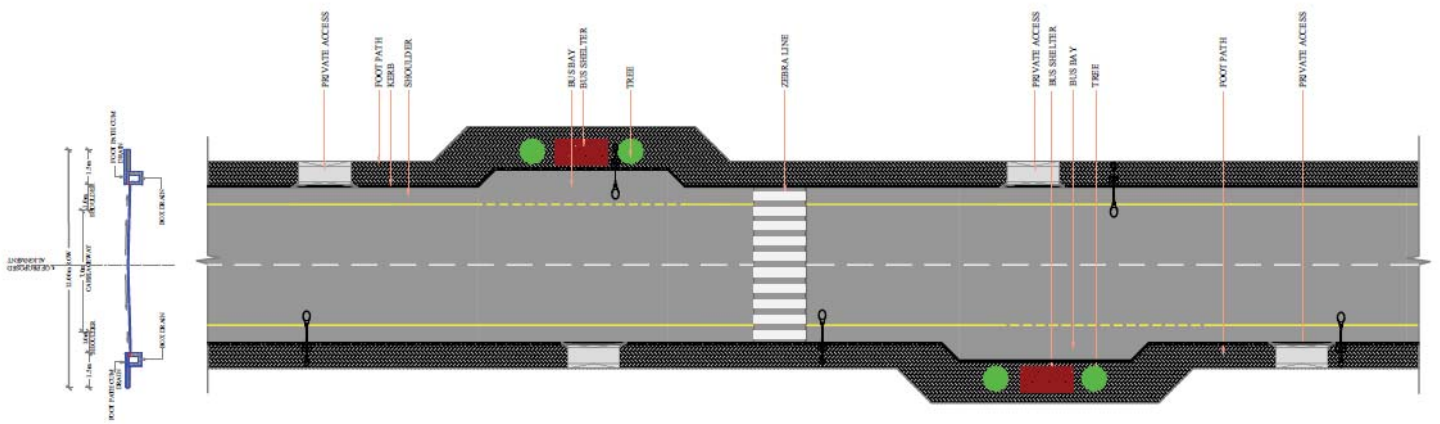

Figure 5.4 Typical layout of 12m Right of way with 7m carriageway

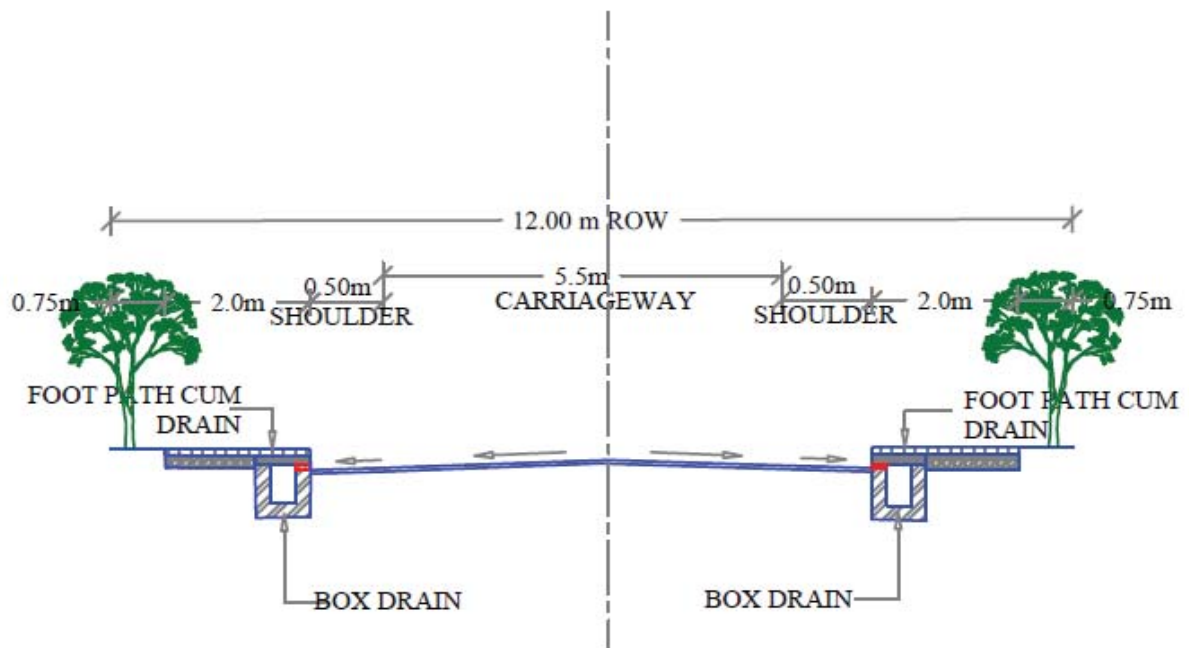

Figure 5.5 Typical cross section of 12m Right of way with 5.5m carriageway

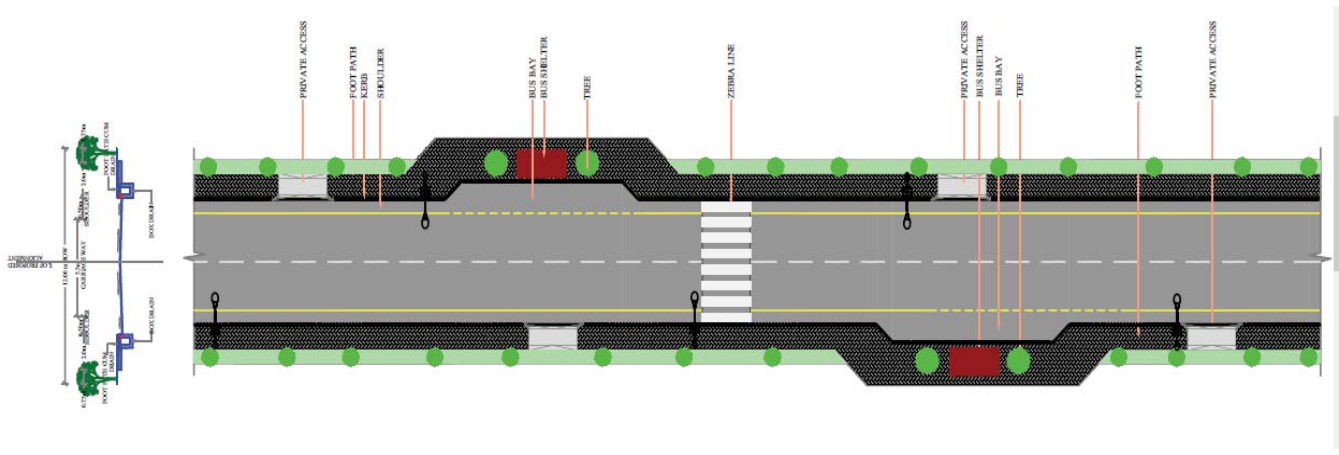

Figure 5.6 Typical layout of 12m Right of way with 5.5m carriageway

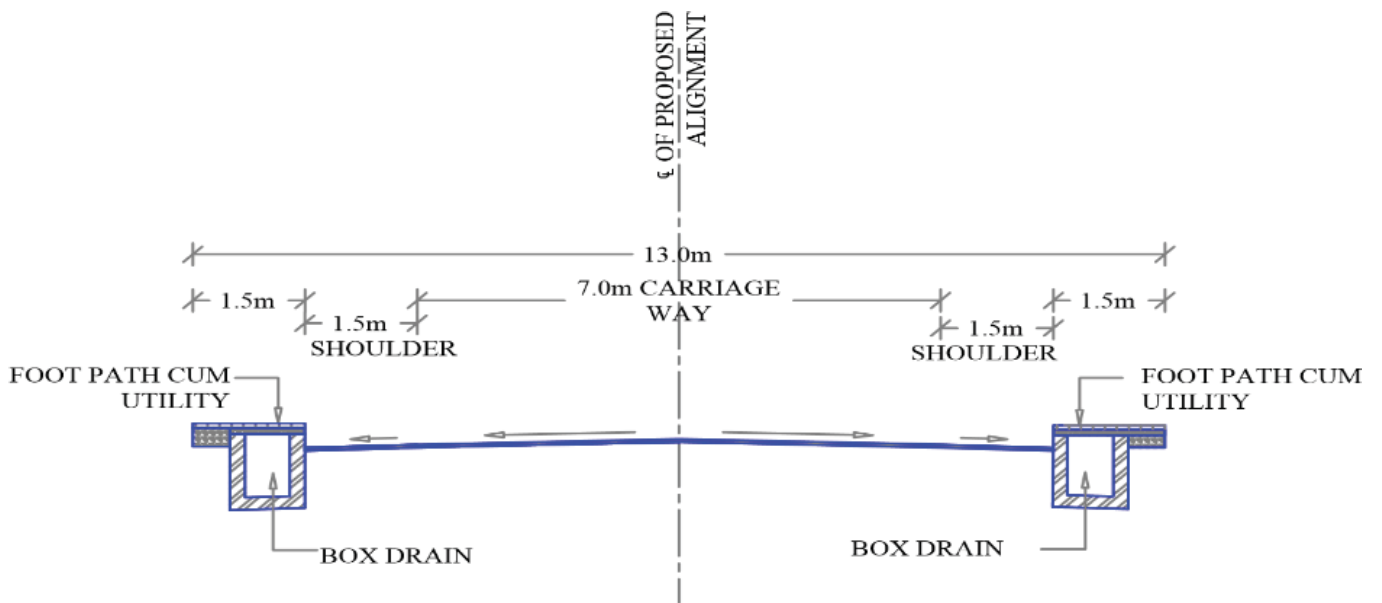

Figure 5.7 Typical cross section of 13m Right of way

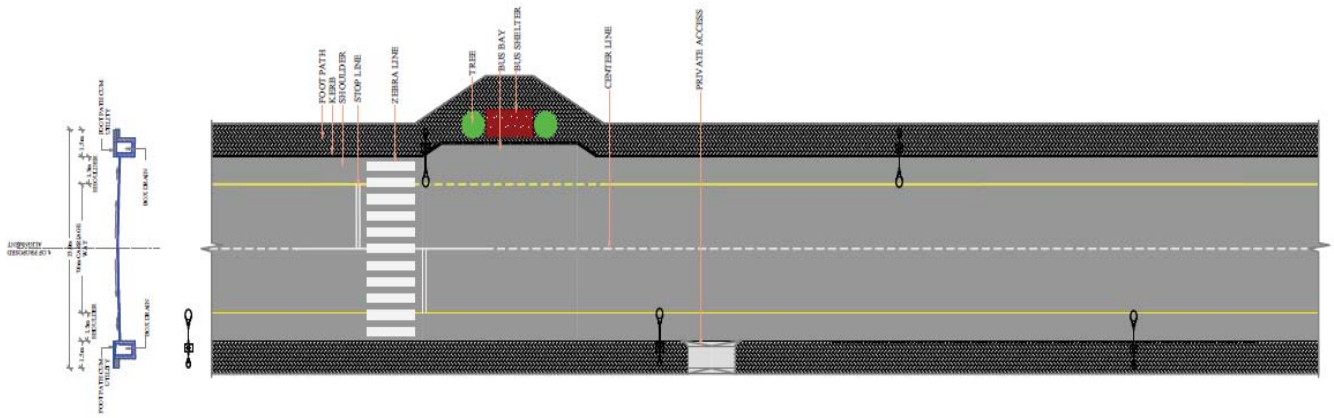

Figure 5.8 Typical layout of 13m Right of way

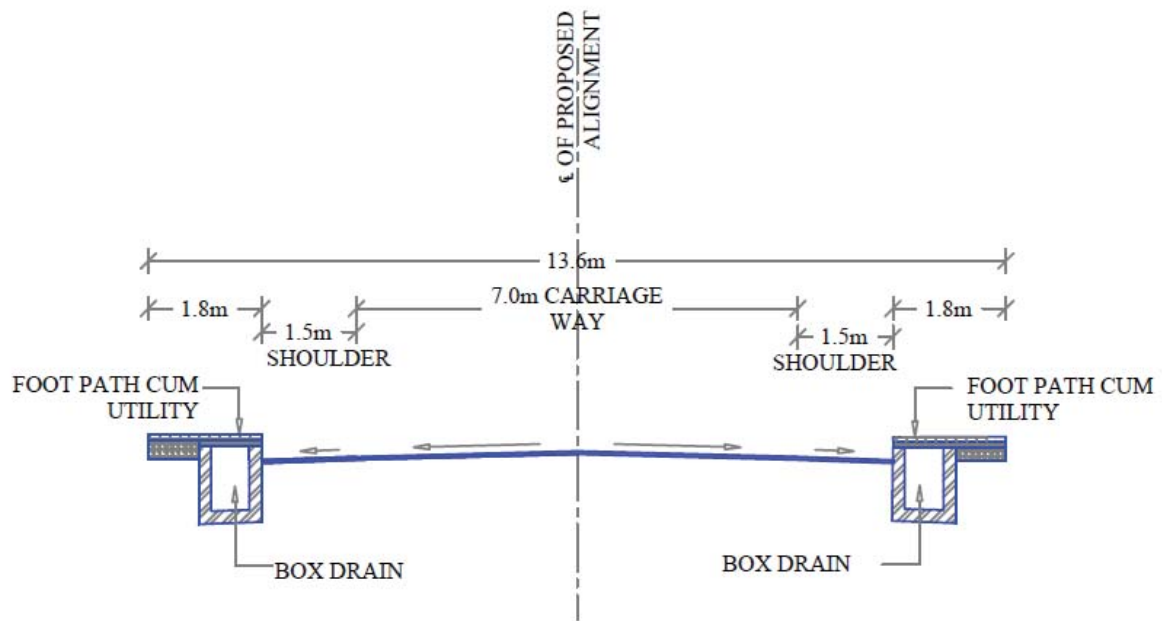

Figure 5.9 Typical cross section of 13.6m Right of way

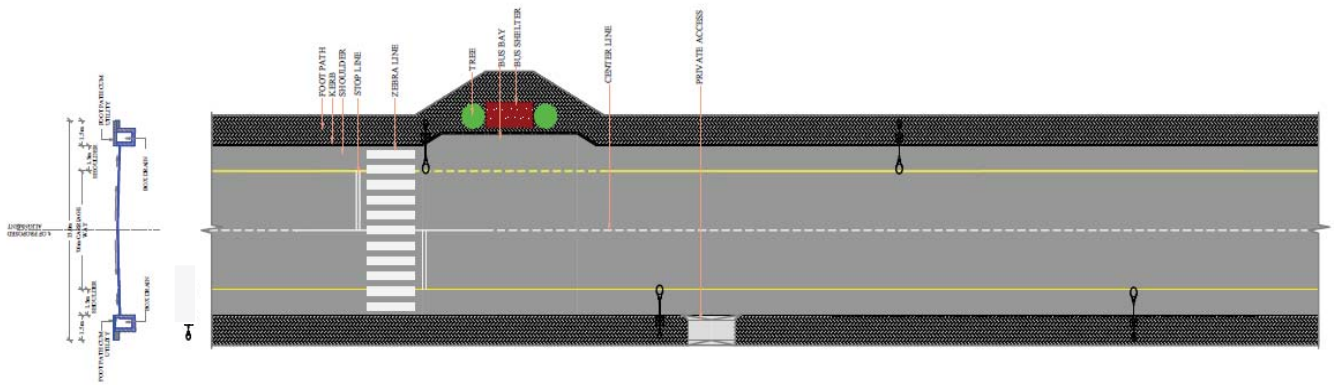

Figure 5.10 Typical layout of 13.6m Right of way

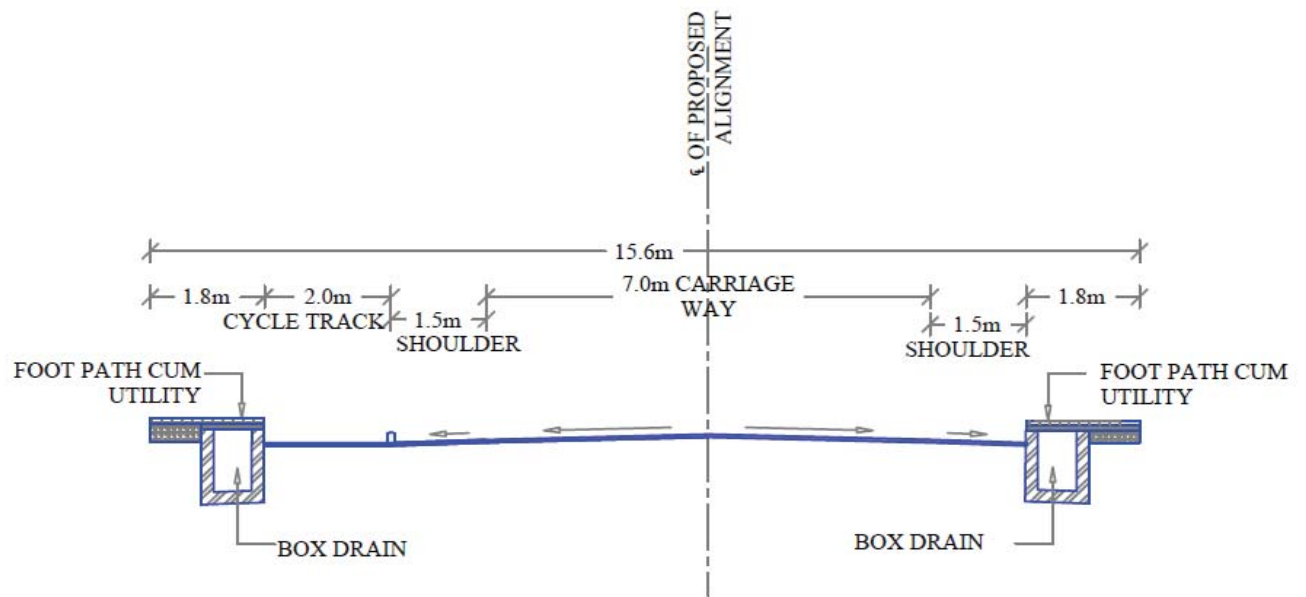
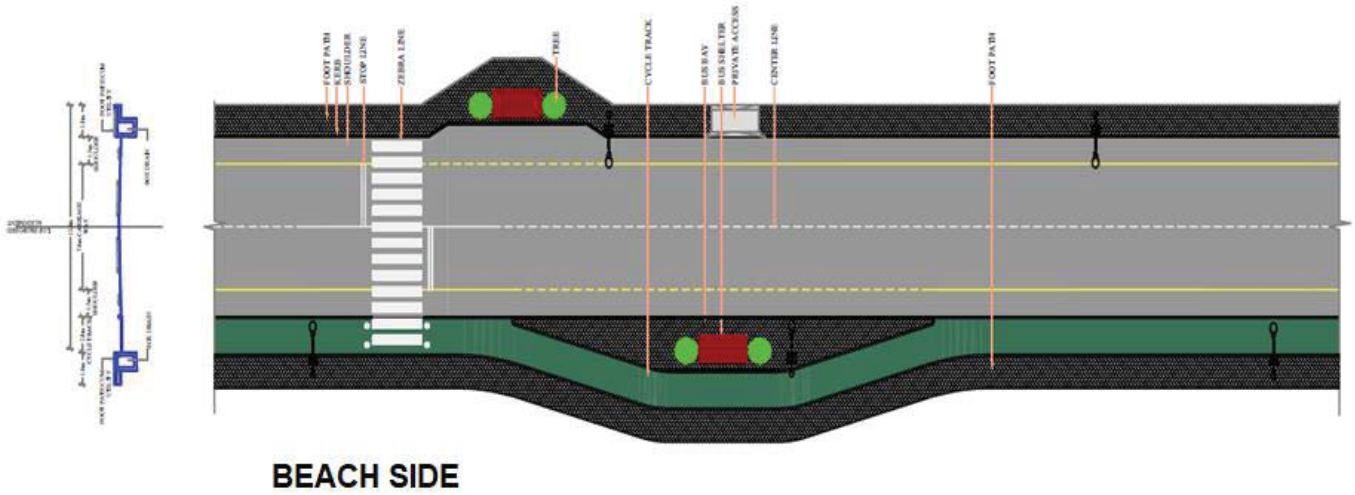

Figure 5.11 Typical cross section of 15.6m Right of way



BEACH SIDE

Figure 5.12 Typical layout of 15.6m Right of way

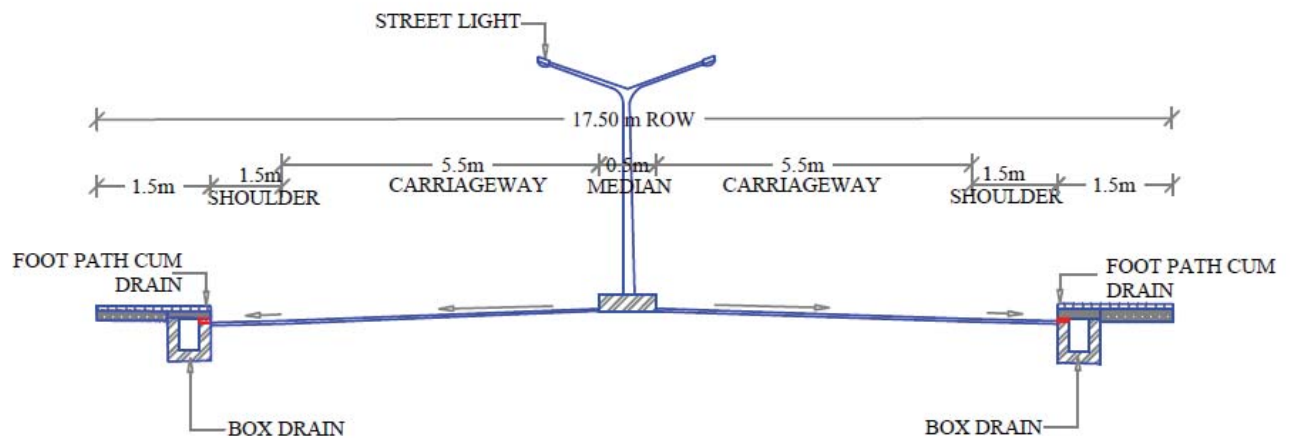

Figure 5.13 Typical cross section of 17.5m Right of way

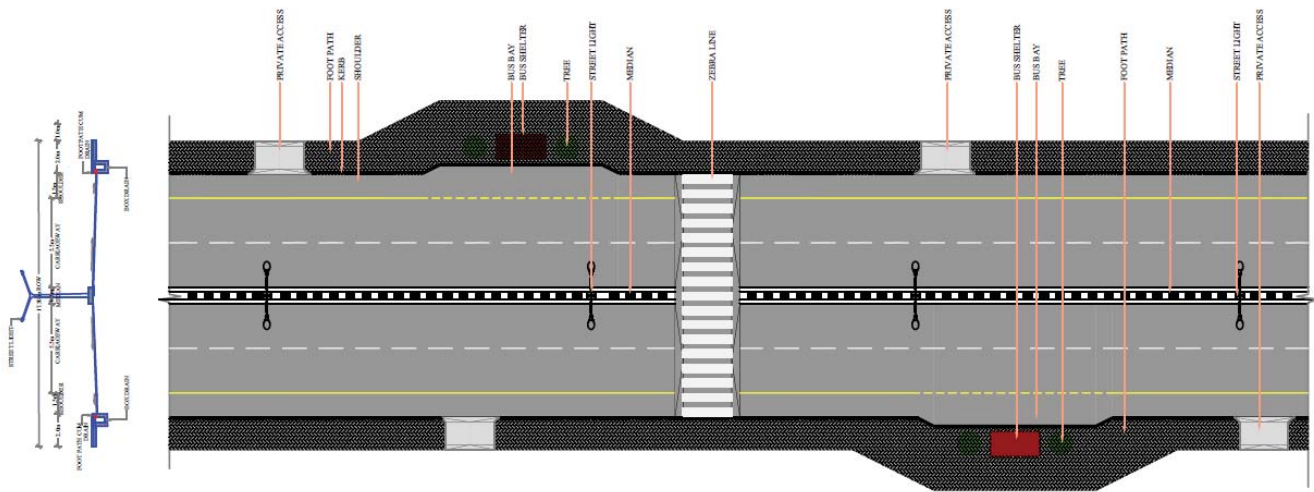

Figure 5.14 Typical layout of 17.5m Right of way

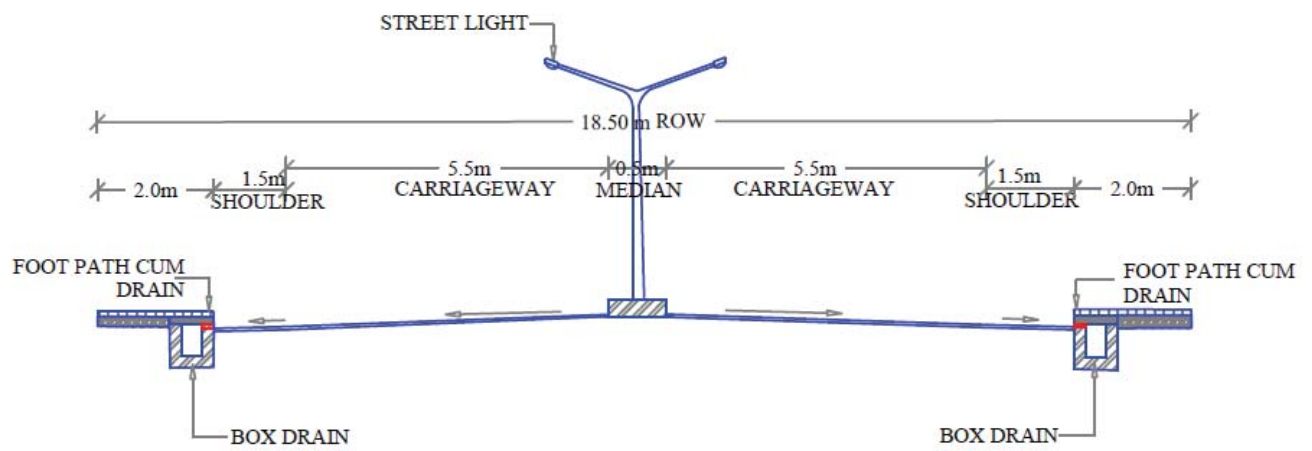

Figure 5.15 Typical cross section of 18.5m Right of way

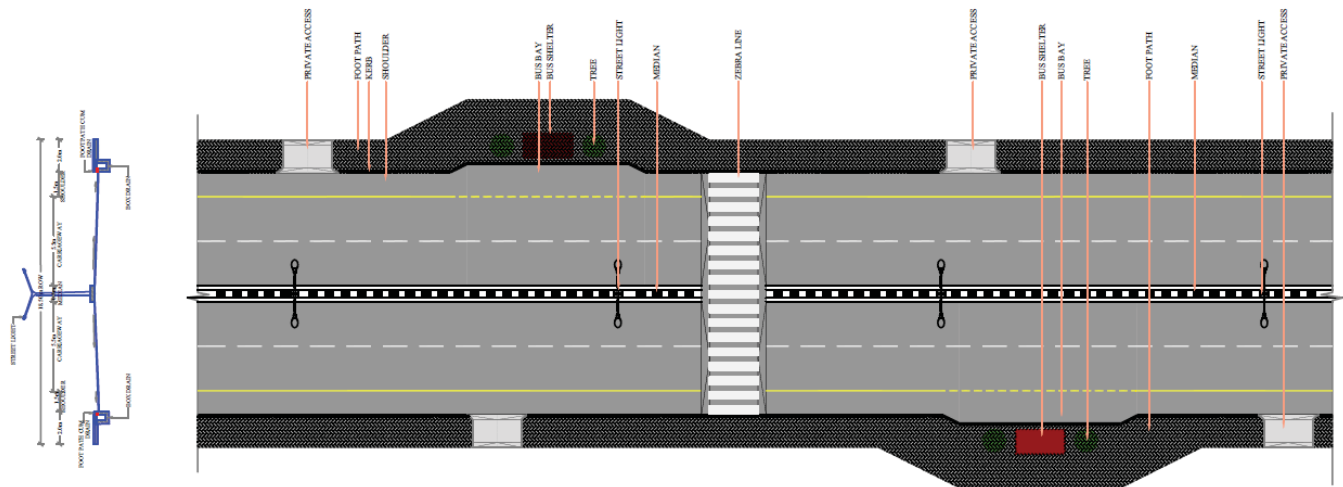

Figure 5.16 Typical layout of 18.5m Right of way

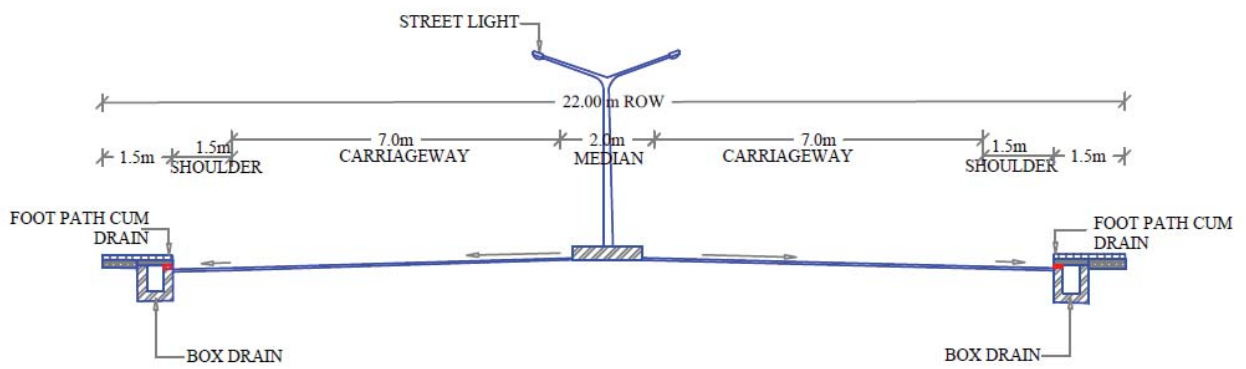

Figure 5.17 Typical cross section of 22m Right of way

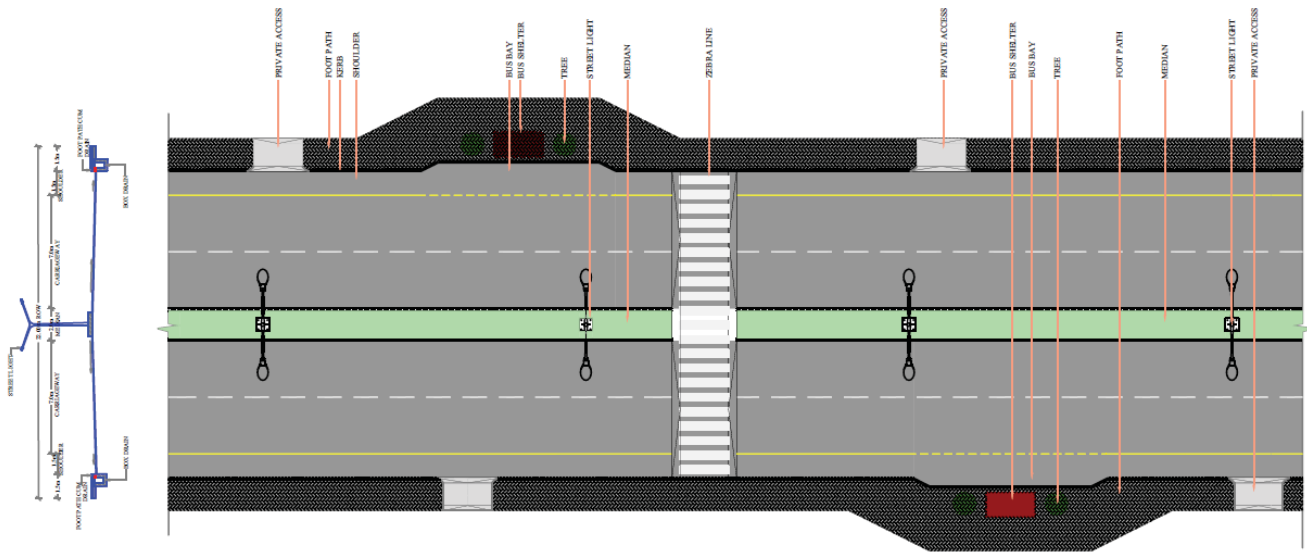

Figure 5.18 Typical layout of 22m Right of way

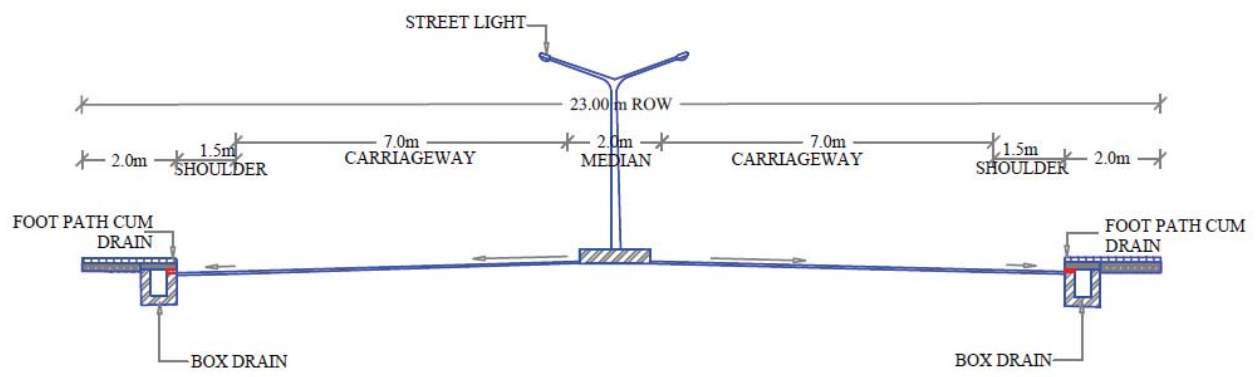

Figure 5.19 Typical cross section of 23m Right of way

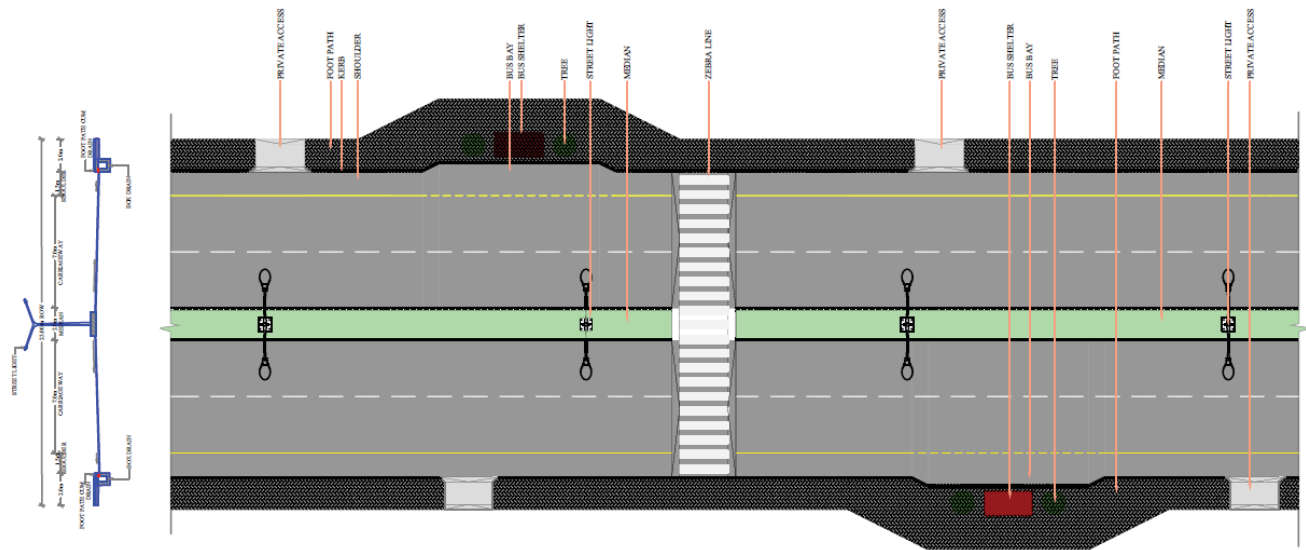

Figure 5.20 Typical cross section of 23m Right of way

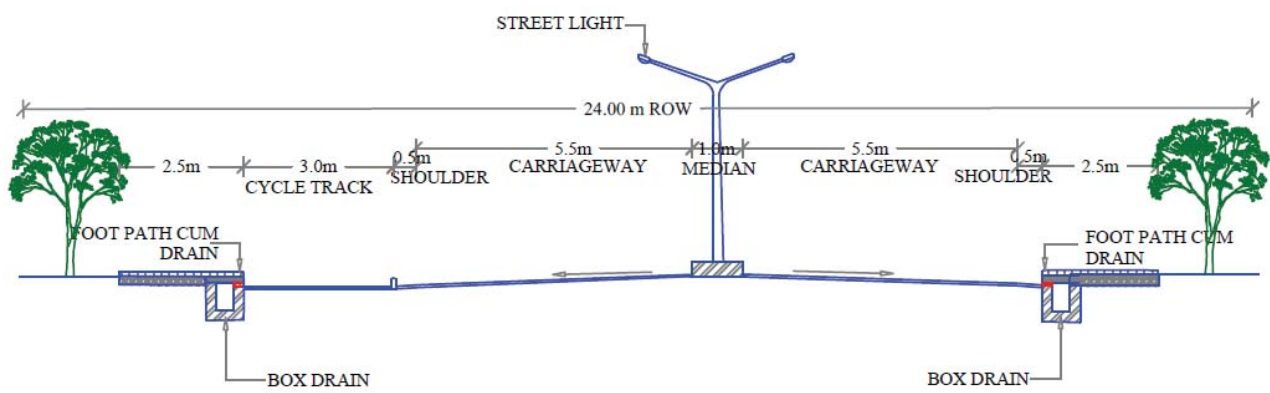

Figure 5.21 Typical cross section of 24m Right of way

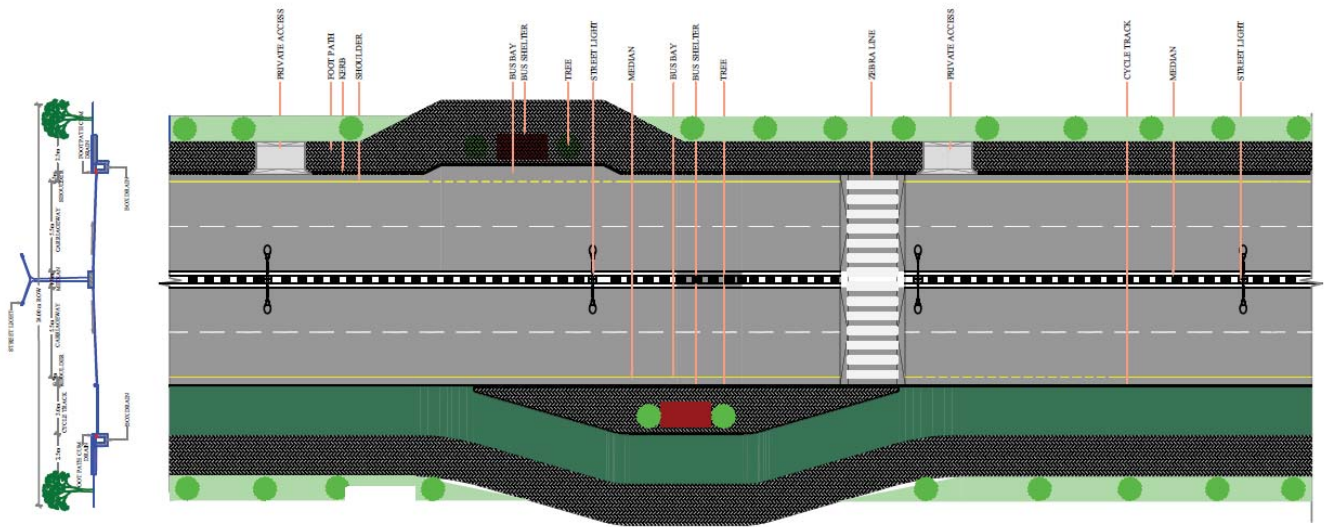

Figure 5.22 Typical layout of 24m Right of way

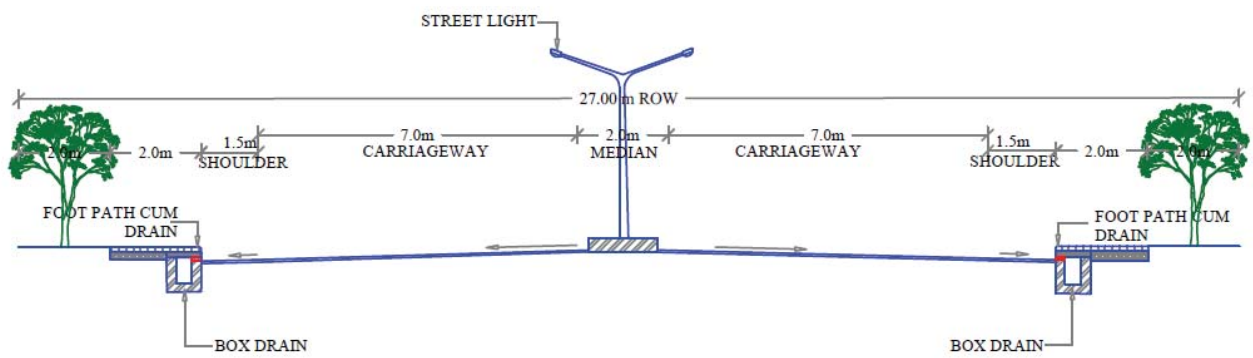

Figure 5.23 Typical cross section of 27m Right of way

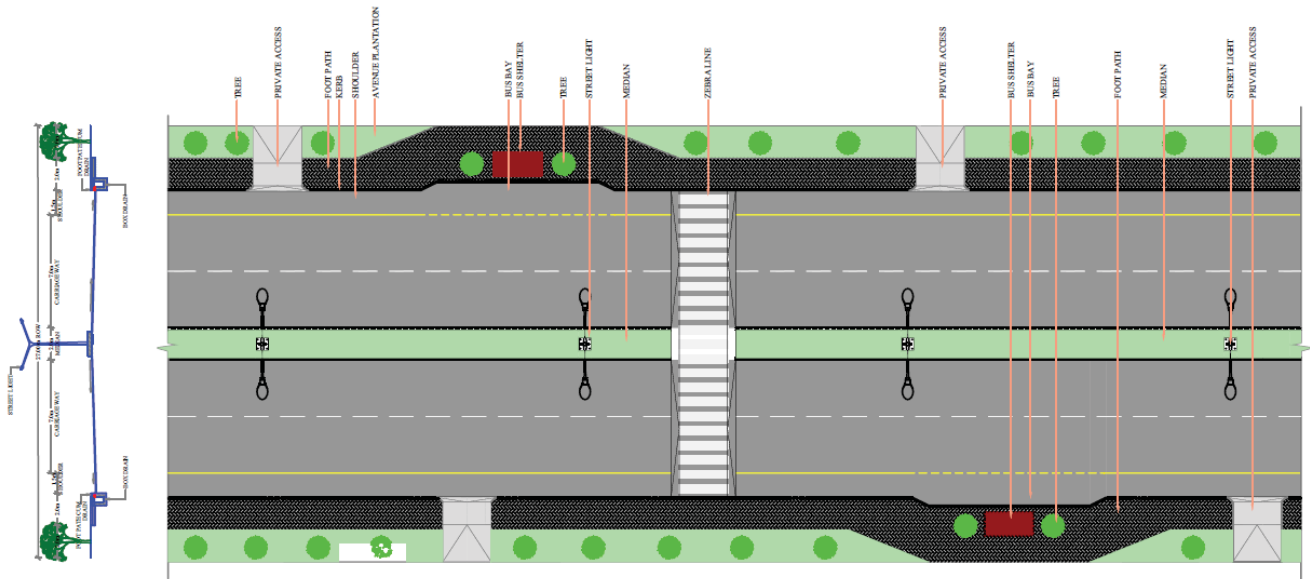

Figure 5.24 Typical layout of 27m Right of way

Chapter – 6

ROADWAY DESIGN

6.1 GEOMETRIC DESIGN AND ALIGNMENT PLANNING



The geometric design of roads deals with the dimension and layout of visible features of the roadway such as horizontal and vertical alignment, sight distances and intersections. The geometrics of roadway should be designed to provide efficiency in traffic operations with maximum safety at a reasonable cost.

The design engineer must consider the following points while selecting the design standards for a roadway:

- i. Adequate geometric design in planning a roadway facility will ensure that the facility will meet the future requirements of traffic demand. Hence the volume and composition of traffic in the design year should be the basis of design.
- ii. Faulty geometrics are costly, if not impossible to rectify at later date and so, due consideration should be given to geometric design at the initial stage itself.
- iii. The design should be consistent, and the standards proposed for the different elements should be compatible with one another. Abrupt changes in the design should be avoided.
- iv. The design should embrace all aspects of geometrics of the road, including signs, markings, proper lighting, intersections, etc.
- v. The roadway should be considered as an element of the total environment and its location and design should enhance rather than degrade the environment. The roadway should be aesthetically satisfying. The design elements should strive to control pollution.



- vi. The design should be so selected that not only based on the initial cost of construction of the facility, but also considering the total transportation cost, including maintenance coat and road user cost so that the total life cycle cost is the lowest.
- vii. Safety should be built into the design elements.
- viii. The design should enable all road users (motors vehicles, animal-drawn vehicles, cyclists and pedestrians) to use the facility. The performance of the vehicle using the facility should be given due consideration.



6.2 DESIGN SPEED GUIDELINE

The design speed, as noted earlier, is the single most important factor in the design of horizontal alignment. The design speed depends up on both type of road and terrain of the road.

A plain terrain can afford to have a flexible geometry, but to maintain the same standard in a hilly terrain, it requires substantial cutting and filling implying exorbitant costs as well as safety concern due to unstable slopes. Therefore, the design speed is normally reduced for terrains with steep slopes due to restrictions in road geometrics.

Table 6.1 Design speed guide lines

Sl No	Nature Classification	Design Speed (km/h)								Corresponding category in IRC
		Plain		Rolling		Mountainous		Steep		
		Ruling	Min.	Ruling	Min.	Ruling	Min.	Ruling	Min.	
1	Coastal Highway	65	50	50	40	30	25	25	20	ODR in Non-Urban Highways
2	Hill Highway	80	65	65	50	40	30	30	20	MDR / MDR in Hill Roads
3	State Highways / By Pass / Ring roads (NH & SH)	100	80	80	65	50	40	40	30	State Highway
4	Other KIIFB Roads (ODR)	65	50	50	40	30	25	25	20	ODR in Non-Urban Highways
5	Other KIIFB Roads (MDR)	80	65	65	50	40	30	30	20	MDR in Non-Urban Highways

- a) In general, the ruling design speed shall be adopted for the various geometric design features of the road.
- b) The minimum design speed shall be adopted only where site conditions are restrictive and adequate land width is not available

6.3 HORIZONTAL ALIGNMENT

The position or the layout of the centre line of the highway on the ground is called alignment. The horizontal alignment includes the straight path, the deviations and horizontal curves.

While designing the horizontal alignment, the following general principles shall be kept in view:

- a) Alignment shall aesthetically merge and blend with the surrounding topography.
- b) For new roads, the curves shall be designed to have a largest practically possible radius, but in no case less than the ruling minimum radius corresponding to ruling design speed.
- c) The curves shall be sufficiently long, and they should have suitable transitions to provide riding safety and pleasing appearance.
- d) Long tangent sections exceeding 3km in length shall be avoided as far as possible.
- e) Reverse curves shall be avoided as far as possible. Where unavoidable, sufficient length between the two curves shall be provided for the introduction of requisite transition curves.
- f) Curves in the same direction, separated by short tangents known as broken back curves, shall be avoided as far as possible.
- g) Design of vertical curves and its coordination with horizontal curves shall be in accordance with IRC:SP:23
- h) Hairpin bends on hilly terrain shall be avoided as far as possible. They should be designed as per the Hill Roads Manual/relevant IRC



6.3.1 TRANSITION CURVES

Transition curves are necessary for the vehicle to have a smooth entry from a straight section into a circular curve. A properly designed transition curve provides a natural, easy - to - follow path for drivers, such that the lateral force increases and decreases gradually as a vehicle

enters and leaves a circular curve. Transition curves may be appropriate to make it easier for a driver to his or her vehicle within its own lane.

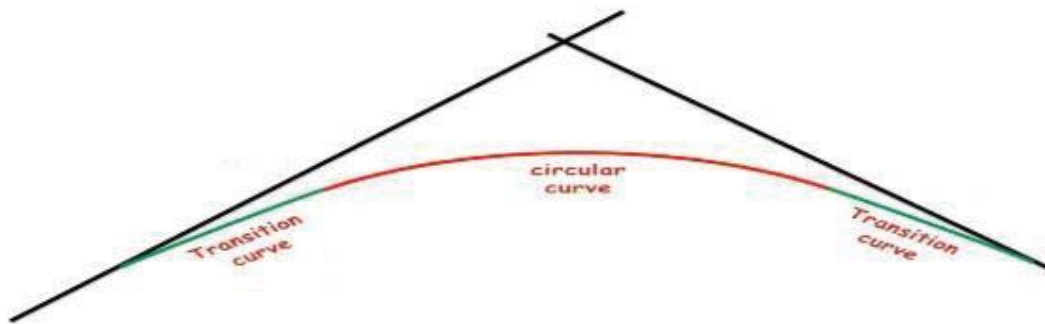

Figure 6.1 Transition curves

- a) Spiral curves are used as transition curves.
- b) The transition spiral is a curve whose degree of curve increases directly as the distance along the curve from the point of spiral.
- c) A spiral transition curve also facilitates the transition in width where the travelled way is widened on a circular curve. Use of spiral transitions provides flexibility in accomplishing the widening of sharp curves.
- d) The geometric design standards for rural roads viz: IRC:73 / KIIFB guidelines should be followed.
- e) Geometrical design for curves, etc. shall be as per MoRTH / IRC applicable for minimum ODR Standards
- f) Length of transition curves selected based on curve radius, design speed and terrain as per
 - ❖ IRC:86 for Urban Highway
 - ❖ IRC:73 for Non-Urban Highway

6.3.2 EXTRA WIDENING

The extra width of pavement at Horizontal curves are provided due to Mechanical properties of vehicle and Psychological parameters of road users.

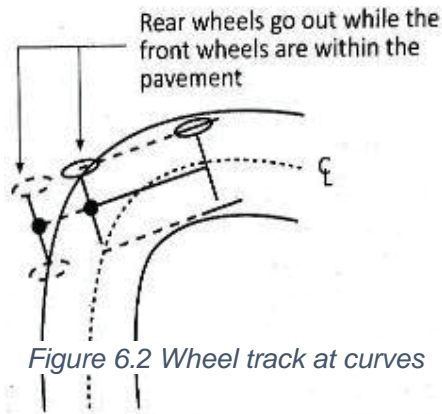

Table 6.2 Extra width provided corresponding to the radius of the curve in two-lane road as per IRC: 73

Radius of Curve	Extra Width
Below 40	1.5m
40 - 61m	1.2m
61-100 m	0.9 m
101-300 m	0.6 m
Above 300m	nil

- For multi-lane roads, the pavement widening may be calculated by adding half the widening for two-lane roads to each lane.
- The increase in the width should be at uniform rate along the length of the transition curves.
- Extra width should be continued over the full length of the circular curve.
- At curves with no transition provide widening with two-third being attain on the straight section before the start of the curve and one-third on the curve.
- Widening should be applied equally on both sides of the carriageway, except hill roads.
- On hilly roads, entire widening is to be done only on the inside of the curve.

6.3.3 OVERTAKING ZONE

For a higher level of service on undivided roads, it is necessary that vehicle moving at design speed should be frequently able to overtake vehicle slower than them. Since overtaking manoeuvre involves the occupation of road space normally used by opposing traffic, drivers must have sufficient sight distance available to them so that the whole operation can be accomplished. The overtaking sight distance can be adopted corresponding to the design speed as per IRC: 66



Table 6.3 Overtaking distance corresponding to design speed as per IRC: 66

Speed (kmph)	Safe overtaking sight distance
40	165
50	235
60	300
65	340
80	470

Overtaking zones are provided when Overtaking Sight Distance (OSD) is not possible to be provided throughout the length of the highway especially in hilly roads. These are zones dedicated for overtaking operation, marked with wide roads. The desirable length of overtaking zones is 5-times the required Overtaking Sight Distance and the minimum is 3- times Overtaking Sight Distance.

6.4 VERTICAL ALIGNMENT

The vertical alignment should provide for a smooth longitudinal profile consistent with the category of the road and layout of the terrain.

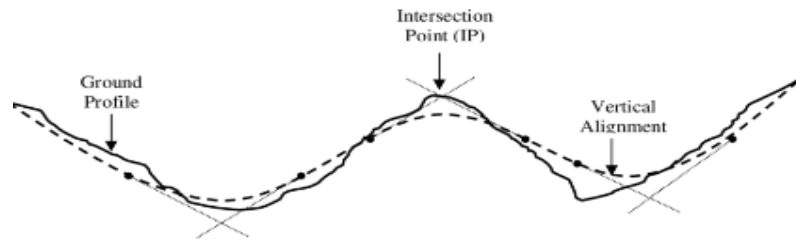

Figure 6.3 Vertical Alignment

6.4.1 VERTICAL CURVES

Vertical curves are introduced for a smooth transition at grade changes. Convex vertical curves are known as summit curves and concave vertical curves as a valley or sag curves. Both of these should be designed as per relevant IRC. The length of the vertical curves is controlled by sight distance requirements, but curves with greater length are aesthetically better. For the satisfactory and smooth drive, a minimum length of vertical curves should be provided.

Table 6.4 Minimum length of vertical curves

Minimum Length of Vertical Curves (as per IRC:73)	Design Speed, (kmph)	Minimum length of curve, (m)	Maximum Grade change, (%)
	35	15	1.5
	40	20	1.2
	50	30	1.0
	65	40	0.8
	80	50	0.6
	100	60	0.5

- Grade changes should not be too frequent as to cause kinks and visual discontinuities in profile.
- Broken back guideline, i.e. two vertical curves in the same direction separated by small tangent should avoid due to poor appearance and preferably replaced by a long curve.
- Deck of small cross drainage structures (i.e. culverts and minor bridges) should follow the same profile as the flanking road section, without any break in grade line.
- While designing a road the amount of material from cuts roughly matches the amount of fill needed so as to minimize the amount of material and construction.

6.4.2 GRADIENT

The grade should be carefully selected keeping in view design speed, terrain conditions and nature of traffic expected on road.

Table 6.5 Gradients of the road in different terrain as per IRC:73

Terrain	Ruling gradient	Limiting gradient	Exceptional gradient
Plain or rolling	3.3 percentage (1 in 30)	5 percentage (1 in 20)	6.7 percentage (1 in 15)
*Mountainous terrain and steep terrain having elevation more than 3000 from mean sea level	5 percentage (1 in 20)	6 percentage (1 in 16.7)	7 percentage (1 in 14.3)
*Steep terrain up to 3000m above mean sea level	6 percentage (1 in 16.7)	7 percentage (1 in 14.3)	8 percentage (1 in 12.5)

* The rise in elevation over a 2km length shall not exceed 100m in mountainous terrain and 120m in steep terrain.

Ruling gradients shall be adopted as far as possible. Limiting gradients shall be adopted in difficult situations and for short length.

6.4.3 SIGHT DISTANCE CONSIDERATIONS

The safe and efficient operation of vehicles on the road depends on the visibility of the road ahead of the driver. Thus, the geometric design of the road should be done such that any obstruction on the road length should be visible to the driver from the minimum desired distance ahead.

Sight distance available from a point is the actual distance along the road surface, over which a driver from a specified height above the carriage way has visibility of stationary or moving objects. Mainly four sight distance situations are considered for design:

- (i) Stopping sight distance (SSD) or the absolute minimum sight distance
- (ii) Intermediate sight distance (ISD) is defined as twice SSD
- (iii) Overtaking sight distance (OSD) for safe overtaking operation
- (iv) Head light sight distance (HSD) is the distance visible to a driver during night driving under the illumination of head lights

Table 6.6 Length of vertical curves for different speed when the length of curves is greater than sight distance. (as per IRC: SP:23)

Design Speed (km/h)	Length of summit curves (m) for			Length of valley curves (m) for headlight distance
	Stopping sight distance	Intermediate sight distance	Overtaking sight distance	
20	0.9A	1.7A		1.8A
25	1.4A	2.6A		2.6A
30	2.0A	3.8A		3.5A
35	3.6A	6.7A		5.5A
40	4.6A	8.4A	28.4A	6.6A
50	8.2A	15.0A	57.5A	10.0A
60	14.5A	26.7A	93.7A	15.0A
65	18.4A	33.8A	120.4A	17.4A
80	32.6A	60.0A	230.1A	25.3A
100	73.6A	135.0A	426.7A	41.5A
Where, A is the algebraic difference between grades expressed as a percentage				

6.4.4 CAMBER/CROSS FALL

The camber on straight sections of roads shall be as indicated in the table for various types of surfaces. Camber is provided to remove the rainwater from the pavement surface as quickly as possible and to allow the pavement to get dry soon after the rain.

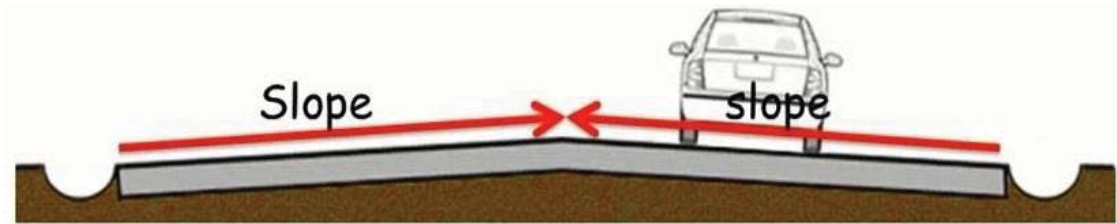

Figure 6.4 Chamber slope

Table 6.7 Camber/Cross fall slope values for different road surface types.

Sl. No.	Surface Type	Camber/Cross fall
1	Thick type bituminous surfacing (more than 40 mm) or cement concrete surfacing	1.7-2.0 percent (1 in 60 to 1 in 50)
2	Thin bituminous surfacing (Less than 40mm)	2.0-2.5 percent (1 in 50 to 1 in 40)
3	Shoulders along unkerbed pavements	At least 0.5 percent steeper than carriageway pavement

The two-lane roads shall be provided with a crown in the middle. On horizontal curves, the carriageway shall be super elevated.

6.4.5 SUPER ELEVATION

Super- elevating on curves is intended to counteract a part of the centrifugal force, the remaining part being resisted by the lateral friction.

Super elevation required on horizontal curves should be calculated from the following formula. This assumes the centrifugal force corresponding to three fourth the design speed is balanced by superelevation and rest counteracted by side friction.

$$e = \frac{v^2}{225R}$$

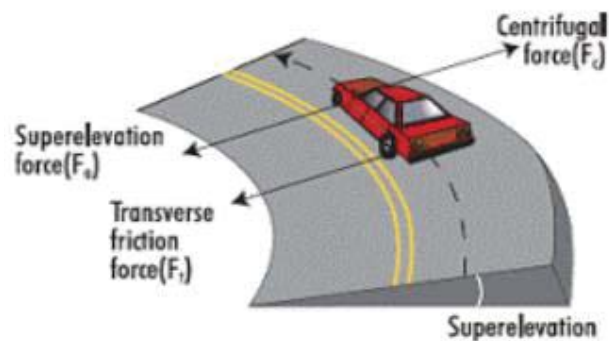

Figure 6.5 Supper elevation

where,

e = superelevation in metre per metre

V = speed in km/h

R = radius in metres

Super elevation shall be limited to 7 percent, if the radius of the curve is less than the desirable minimum. It shall be limited to 5 percent, if the radius is more than the desirable minimum and also at the section where Project Highway passes through an urban section or falls on a major junction.

6.5 HILLY ROADS

The hilly regions generally have extremes of climatic conditions, difficult and hazardous terrains, topography and vast high-altitude areas. For the purpose of efficient and safe operation of vehicles through a hilly terrain special care should be taken while aligning the highway. Some of the special considerations for highway alignment through a hilly terrain is discussed below.

Stability of the slopes: for hilly areas, the road should be aligned through the side of the hill that is stable. The common problem with hilly areas is that of landslides. Excessive cutting and filling for road constructions give way to steepening of slopes which in turn will affect the stability.

Hill side drainage: Adequate drainage facility to avoid water flow through pavement surface should be provided across the road. Attempts should be made to align the roads in such a way where the number of cross drainage structures required are minimum. This will reduce the construction cost.

Special geometric standards: The geometric standards followed in hilly areas are different from those in flat terrain. The alignment chosen should enable the ruling gradient to be attained in a minimum of the length, minimizing steep gradient, hairpin bends and needless rise and fall.

Ineffective rise and fall: Efforts should be made to keep the ineffective rise and excessive fall minimum.

Some additional features are required for hilly terrain to safe geometric design.

6.5.1 HAIR- PIN BENDS

A hair-pin bend may be designed as a circular curve with transition curves at each end. Alternatively, compound circular curves may be provided.



Figure 6.6 Hair-pin bends (a) & (b)

6.5.2 GRADE COMPENSATION ON CURVES

On hilly roads, it is necessary to ease the gradients at horizontal curves by an amount known as the grade compensation. This is intended to offset the extra tractive effort involved at curves.

Grade compensation (per cent) = $\frac{30+R}{R}$, subject to a maximum of $\frac{75}{R}$

Where, R = radius of the curve in m.



Figure 6.7 Grade compensation

Since grade compensation is not necessary for gradients flatter than 4 per cent. In applying for compensation, the gradient need not be eased beyond 4 per cent.

6.5.3 CLIMBING LANE

Hilly roads at restricted overtaking opportunities and presence of slow-moving vehicles can result in substantial congestion and high accident rates through injudicious overtaking.

Climbing lanes may be provided wherever necessary in order to address the necessity of making available a separate lane for safe overtaking for a vehicle



Figure 6.8 Climbing lane

travelling uphill, in reaches having continuous exceptional gradients.



Chapter – 7

PAVEMENT ENGINEERING DESIGN

Pavement engineering design consists of determining the thickness of individual pavement or the combinations of materials and technologies in layers in order to serve traffic for an anticipated design period. The design depends on various factors, such as intensity of traffic wheel loads, repetitions, temperature, rainfall, humidity, drainage conditions, sub-grade soil strength, properties of materials used, criteria of mix design and economic considerations. Pavement design mainly depends upon the sub-grade strength and axle load on road.

7.1 GROUND IMPROVEMENT TECHNIQUES

Ground improvement techniques are recommended in difficult ground conditions as mechanical properties are not adequate to bear the superimposed load of infrastructure to be built, swelling and shrinkage property more pronounced, collapsible soils, soft soils, organic soils and peaty soils, foundations on dumps and sanitary landfills, handling dredged materials for foundation beds, handling hazardous materials in contact with soils, using of old mine pits as site for proposed infrastructure. The engineering techniques of ground improvement are removal and replacement, pre-compression, vertical drains, in-situ densification, grouting, stabilization using admixtures, reinforcement, etc. The purpose of adopting these techniques is to increase the bearing capacity of the soil and reduce the settlement to a considerable extent by ensuring the concept of sustainability in construction projects and also to reduce the thickness of the pavement layers and the consequent reduction in aggregate consumption; improved performance and lower life cycle cost.

Selection processes for ground improvement methodologies, improved analysis, and knowledge of long-term performance and understanding of the effects of variability are required to develop more efficient designs.

7.1.1 MECHANICAL IMPROVEMENT TECHNIQUES

In this method, soil density is increased by the application of mechanical force, including compaction of layers by conventional steel roller and by vibratory rollers. This technique is further classified as: -

- a. Dynamic Compaction
- b. Vibro-Compaction
- c. Compaction Grouting
- d. Pre-loading and Pre-Fabricated Vertical Drains
- e. Blast densification

7.1.2 HYDRAULIC MODIFICATION TECHNIQUES

The modification of soil properties is achieved by forcing the free pore water out of soil via drains or wells. In case of coarse-grained soils, it is achieved by lowering the groundwater level through pumping from boreholes, or trenches and for fine-grained soils the long-term application of external loads (preloading) or electrical forces (electrometric stabilization). Some of the hydraulic modification methods are: -

- a. Preloading using fill
- b. Preloading using fill with vertical drain
- c. Vacuum preloading with vertical drains
- d. Combined fill and vacuum preloading

7.1.3 PHYSICAL AND CHEMICAL MODIFICATION TECHNIQUES

In this method, soil improvement is achieved by physical mixing of adhesives with surface layers or columns of soil. The adhesive includes natural soils industrial by-products or waste materials or cementations or other chemicals which react with each other and the ground. When adhesives are injected via boreholes under pressure into voids within the ground or between it and a structure the process is called grouting. Soil stabilization by heating and by freezing the ground is considered thermal methods of modifications. Some of the physical and chemical modification methods are: -

- a. Grouting
- b. Electro-osmosis
- c. Soil Cement
- d. Heating
- e. Vitrification

7.1.4 MODIFICATION TECHNIQUES BY INCLUSION AND CONFINEMENT

In this method modification of soil properties are achieved using reinforcement by means of fibres, strips bars mesh and fabrics impart tensile strength to a constructed soil mass. In-situ reinforcement is achieved by nails and anchors. Stable earth retaining structure can also be formed by confining soil with concrete, steel, or fabric elements and Geocell. There has been a large increase in the use of admixtures for ground improvement for both cohesive and non-cohesive soil in recent years.

- a. Sand compaction piles
- b. Stone columns
- c. Dynamic replacement
- d. Semi-rigid and rigid inclusions
- e. Geotextile confined columns

7.1.5 MICROBIAL METHODS

In this technique, the microbial materials are used to modify soil to increase its strength or reduce its permeability. The principle of microbial treatment is to use microorganisms produce bonding and cementation in the soil so as to increase the shear strength and reduce the permeability of soil or rock. Suitable microorganisms for the purpose are:

- a. Facultative anaerobic bacteria
- b. Micro-aerophilic bacteria
- c. Anaerobic fermenting bacteria
- d. Anaerobic respiring bacteria
- e. Obligate aerobic bacteria

7.1.6 GEOSYNTHETICS

Geotextiles and geomembranes, broadly speaking are synthetic fibres used to stabilize structures built on the soil. This method improves the soil response by the interaction between soil and inclusion. The improving period depends on the life of inclusion. In this technique, there is no change in the state of the soil. It is a widely used technique as it can be done for many types of soils. The new widely accepted generic term for these non-natural materials is Geosynthetics. Geosynthetics include permeable and impermeable materials that are either of knitted, woven, or non-woven nature, as well as polymer grids and meshes. The role of the geosynthetic material varies in the different application as it can serve as reinforcement, separation, filtration, protection, containment, fluid transmission and confinement of soil to improve bearing capacity. These fibres may also be used to provide tensile strength, redistribution of stresses and of confinement, thereby increasing the stability of a soil mass, reducing earth pressures, or decreasing deformation or susceptibility to cracking. Geocell reinforcement is a recently developed technique in the area of soil reinforcement having a three dimensional, polymeric, honeycomb-like structure of cells made out of geo-grids interconnected at joints.

7.2 PAVEMENT DESIGN

7.2.1 NEW PAVEMENT DESIGN

New pavements shall be designed in accordance with the method prescribed in IRC:37-2012 or any alternative pavement composition methods or improvements methods to reduce pavement thickness. Otherwise, pavement composition and thickness shall not be less than the minimum requirement specified in IRC:37 2012/ IRC: SP:72-2015 depending on the projected traffic for the design life.

The following aspects should consider while designing pavement to achieve better performance.

1. A minimum of 15-year design life should be considered.
2. The select soil forming the subgrade should have a minimum CBR of 8 per cent for roads having the traffic of 2 msa or higher.
3. The pavement layer thickness shall be selected from corresponding CBR plate and traffic and supplemented with results/output from IITPAVE software.
4. Roads having design traffic below 2 msa shall be considered as low volume road and for such roads, the pavement design shall be as per IRC SP: 72-2015.
5. Arterial City roads shall be designed for a minimum of 5 msa traffic.
6. Computation of effective CBR of subgrade for pavement design as per IRC:37-2012.
7. Use of rut resistant surface layer in case of high trafficked highways
8. Use of fatigue resistant bottom bituminous layer in case of high trafficked highways
9. Selection of surface layer to prevent top-down cracking
10. Use of bitumen emulsion/foamed bitumen treated reclaimed asphalt pavements in base/ binder course.
11. Consideration of stabilized sub-base/ base course with locally available soil and aggregates.
12. Design of subsurface drainage layer
13. Computation of design traffic as per IRC:37-2012/IRC: SP:72-2015
14. For the heavy traffic roads design of perpetual pavements with deep strength bituminous layer can be used.
15. The CBR plates and traffic selected for design shall be included with the pavement design.

The new pavement surface shall satisfy the following performance standards at any time during the design life of the pavement:-

- a) Surface finish as per requirements of Clauses 902 and 903 of MORTH Specifications soon after construction.
- b) Roughness in each lane should not more than 2000 mm/km for each lane in a km length
- c) Rutting in wheel path measured by 3 m Straight Edge in each lane should be less than 10mm.
- d) No cracking or any other distress on the carriageway.

7.2.2 OVERLAY DESIGN

The overlay is the difference between the thickness required for a new pavement and the effective thickness of the existing pavement. Pavement deflections can be used to determine the nature and extent of reconstruction for an existing distressed roadway.

Pavement evaluation based on IRC: 81 or IRC: 115 are to be conducted to the characteristic deflection of the existing pavement. Based on a characteristic deflection and the cumulative number of standard axle loads required overlay provided as per IRC:81 and IRC:115 as and when required. The characteristic rebound deflection value for any project road should not exceed 1.0mm any time during the design life.

7.3 ALTERNATIVE PAVEMENT DESIGN

Any method which can reduce the layer thickness of pavement by alternatives design methods for pavements can be adopted on the basis of optimization of material and life-cycle cost of pavement. The proposals submitted shall include a detailed evaluation of alternatives and shall arrive at the most optimal design in the context of road development in Kerala.

- a) Full Depth Reclamation
 - a. Helps in reducing the consumption of construction materials in the wake of shortage of the same in Kerala
 - b. Serves as an environment-friendly and sustainable construction method.
- b) As per the guidelines in IRC: SP: 59 uses of geotextile in pavements and associated works.
- c) Cold recycling of existing bituminous layer with RAP used pavement design method as per IRC:120 -2015
- d) Hot recycling methods on top bituminous layer for improving the riding quality
- e) Micro surfacing / Ultra-thin white topping can adopt based on pavement structural and functions conditions
- f) Permeable pavements for low volume roads
 - Type of pavement surface to allow stormwater runoff to filter through voids in the pavement surface and infiltrated under the drain layer.
 - There are different types of permeable pavement surfaces, including pervious concrete, porous asphalt and permeable interlocking concrete pavers.

Chapter – 8

DRAINAGE SYSTEM

The function of the drainage system in the roadway is removing and controlling excess surface and sub-soil water within the roadway or right of way. Adequate drainage is essential for the protection of the investments made in the roadway structures. Therefore design, construction and maintenance of appropriate drainage system is one of the most important tasks. Roadway drainage system consists of two parts.

- i. Side drain systems
- ii. Cross drain systems

8.1 SIDE DRAIN SYSTEM

- a. A road drainage system designed as per IRC: SP:42- 2014 and must satisfy two main criteria if it is to be effective throughout its design life:
 - i. It must allow for a minimum of disturbance of the natural drainage pattern.
 - ii. It must drain the surface and subsurface water away from the roadway and dissipate it in a way that prevents the excessive collection of water in unstable areas and subsequent downstream erosion.
- b. The depth of drain may be varying according to the stormwater drainage characteristics and lead to the nearest discharge point.
- c. Drainage design is most appropriately included in alignment and gradient planning.
- d. Natural drainage characteristics of a hillslope shall not be changed.
- e. A cross drainage may be provided 20m before the start of the hairpin bend for proper drainage of surface water and adequate drainage may be also be provided on hill side of the bend so that water does not cross road surface.
- f. There are many pre-cast sides available at different depth
- g. Design of drains should be as per IRC: SP- 42 recommendation
- h. Interceptor drains to be provided along hill slopes, where required.



Figure 8.1 side drain

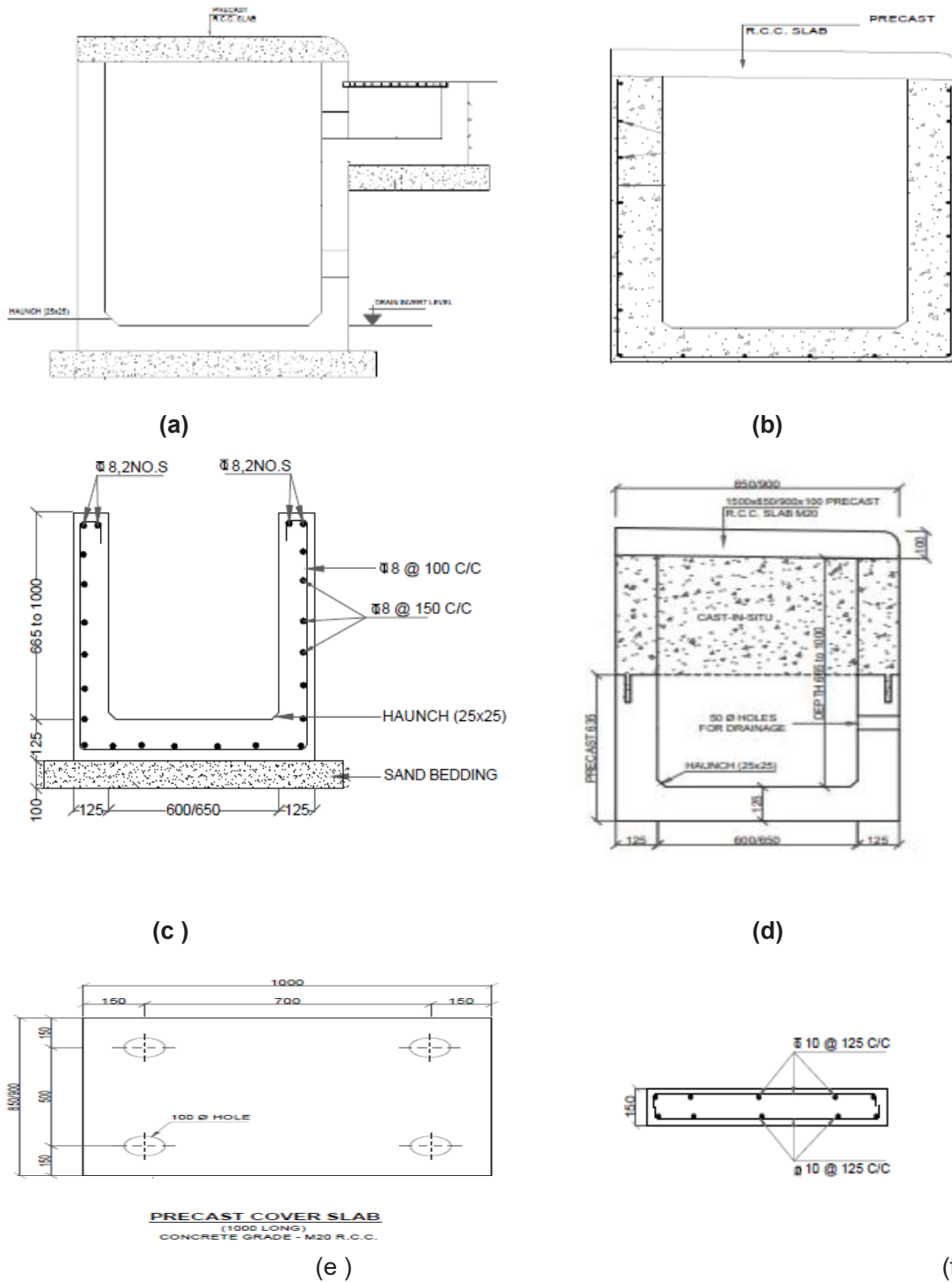

Figure 8.2 Typical sections of (a) Side drain with catch pit & (b) Precast drain with slab (c) cast in situ drain up to 1m depth (d) Precast and extension with cast in situ drain (e) Precast cover slab plan (f) Precast slab section

8.2 CROSS DRAIN SYSTEMS

The water flow along the road side drains are collected by suitable cross drains through cross drainage structures (CD structures) at locations of natural valleys and streams and streams and disposed of to the natural water course.



Figure 8.3 Slab culvert



Figure 8.4 Box culvert



Figure 8.5 Precast box culvert



Figure 8.6 Pipe culvert

- CD structure may generally be a suitable type of culvert, depending on the quantity of water to be carried across and the span.
- A minimum of 1200cm diameter pipe culvert should be selected.
- The CD structures should extend up to the full formation width of the road.
- Ends of CD structure should be protected by suitable abutments and parapet walls.
- The width of river or stream to be crossed more than 6m the minor bridge type cross drain structure adopted.



Figure 8.5 Culvert with abutment

Chapter – 9

UTILITY CORRIDOR AND CROSS DUCT



Figure 9.1 road cutting for utility laying

- a. Utility ducts are provided at suitable depths without obstructing the drainage flow.
- b. Utilities include water supply line, gas pipeline, electricity cables, optical cables, etc.

Utility corridor and cross ducts are provided to avoid frequent damage to roads by digging roads for utility flow and cross duct for utility crossing purpose and this will increase the life of the pavement.



Figure 9.2 Utility duct



Figure 9.3 Utility cross duct

- c. Cross duct for utility should provide at an interval of minimum 500m in populated areas for utility crossing purpose to avoid pavement cross digging.
- d. Utility corridor or duct provide at utility space under to footpath.

Chapter – 10

ROADSIDE AMENITY

10.1 FOOTPATH AND PEDESTRIAN CROSSING



Figure 10.1 foot path

Pedestrians have same importance same as vehicle traffic. There should be separate pedestrian facilities such as side-walk and pedestrian crossing facilities in roads in order to minimize accident injuries and fatalities of the pedestrian.

There should be required space to cater to pedestrian facilities such as raised footpaths, safe crossing facilities at-grade and grade separated crossing facilities at appropriate locations.

- a) Footpath should be designed with Interlocking Concrete Paver Blocks as per IRC: SP:63, and combinations with tactile.
- b) The width of footpath shall be adopted corresponding to pedestrian volume as per IRC: 103.
- c) Utility or drain slab area shall be used as footpath otherwise paved tiles or interlock tiles shall be provided at the footpath area.
- d) Raised footpath with universal design provision for accessibility shall be provided with considering access to the differently abled person.
- e) Table-top pedestrian crossing are to be provided at heavy pedestrian crossing volume road stretches or intersections.
- f) Footpath shall be provided with guard rails at unsafe manoeuvre crossing areas and heavily built-up areas especially in urban areas



Figure 10.2 Tactile patterns

Figure 10.3 Table top pedestrian crossing



Figure 10.3 (a) & (b) Table top pedestrian crossing

10.2 BUS BAYS AND BUS SHELTERS

Bus bays are recommended for new and high-volume roads, other than low-volume roads.

They enable buses to slow down and stop outside the traffic lane, and this greatly reduces the risk of following traffic colliding with them or having to overtake in a panic. Bus bays should be at least 3 m wide and should be placed adjacent to the paved or gravel



Figure 10.4 Bus bay

- a) shoulder so that buses can stop clear of the carriageway.
- b) Bus bay must be long enough to enable the bus to leave the through traffic lanes at approximately the average running speed of the highway without undue inertial discomfort or sideways to passengers
- c) Bus bays should preferably be located on straight, level sections of road with good visibility (at least Stopping Sight Distance).
- d) Bus bays shall not be sited opposite each other, because this can cause safety problems.
- e) Bus bays must be staggered tail to tail so that departing buses move away from each other.
- f) Bus traffic near intersection interferes with the traffic flow. It is desirable that the bus stops should be located at least 50m away from the intersections.



Figure 10.5 Bus shelter models

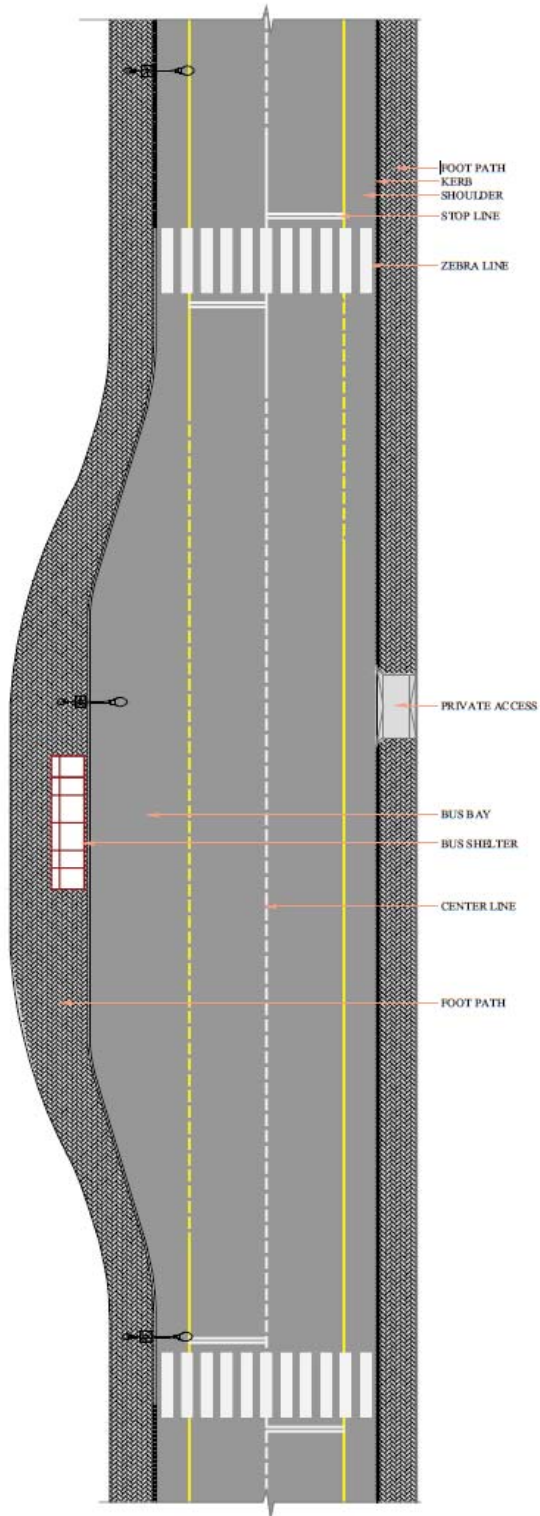

Figure 10.6 Typical layout of the bus bay

10.3 SMART STREET LIGHT



Figure 10.7 Smart street lights

A large proportion of road accidents are caused in the night and one of the chief reasons is the unsatisfactory lighting. Improved visibility at night by means of artificial lighting lessens the strain on driving and ensures comfort. In this modern world, smart street lighting systems with solar powered are available to full fill road lighting requirements.

- a) Streetlight system with solar powered should be encouraged by checking their economic and financial viability.
- b) Streetlight arrangements and span should be selected based on uniform luminance to the pavement surface
- c) There are four type patterns of light arrangements are possible:
 - a. Staggered: either side of the carriageway
 - b. Opposite: either side of carriageway opposite to one another
 - c. Central: axial line close to the centre of the carriageway
 - d. Single-sided: one side of the carriageway
- d) Smart street light with solar-powered light, advertisement light, WiFi routes can provide on streets
- e) Solar powered advertisement display wall with mobile charging points at street or walkway

10.4 CYCLE TRACK

A cycle track is an exclusive bike facility that combines the user experience of a separated path with the on-street infrastructure of a conventional bike lane. A cycle track is physically separated from motor traffic and distinct from the sidewalk.

- a) Cycle tracks should be designed as per IRC:11-2015
- b) Cycle track must be in different pavement colour/texture to separates the cycle track from the sidewalk and motor traffic.
- c) A minimum of 2m width cycle track provided at least a minimum of 5km continues length in city roads, coastal highway stretches, and road stretches having more cycle traffic.
- d) Cycle tracks should be protected by delineators or curb to block motor traffic to the cycle track.



Figure 10.8 Cycle track



Figure 10.9 Cycle shelters

10.5 PARKING

Vehicle parking facilities are constructed to provide a convenient area for travellers to park the vehicles in an organized manner. With the growing population of motor vehicles, the problem of parking has assumed serious proportions. Parking demand is a function of land use. Uncontrolled parking may reduce the carriageway width, and it causes the capacity reduction of the road.

- a) There shall be directional signs guiding people to the accessible parking.
- b) Dedicated parking slots at select stretch considering the traffic requirements and importance of the road stretch.
- c) Based on demand assessment, organised parking space for an auto/taxi should be provided.
- d) Two all accessible parking lots with an overall minimum dimension of 3600 mm wide and 5000mm length (including aisle space), shall be provided.
- e) The parking shall be marked for the physically challenged at the ratio of 2:25 of the total number of parking.



Figure 10.10 Parking

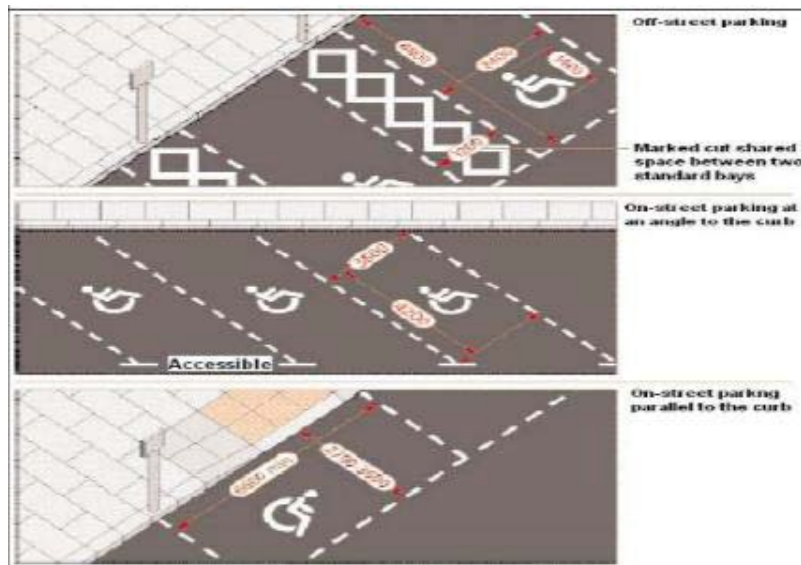

Figure 10.11 Layout for universal parking space



Figure 10.12 Dedicated parking slots

10.6 AMENITY CENTRE

Fatigue is a significant issue for those travelling long distances in the rural road environment.



Figure 10.13 Parking area sign

It is estimated that fatigue is the main contributing factor in approximately 25% of road crashes involving serious injury. The provision of rest opportunities through rest areas represents a management tool in addressing fatigue-related crashes. Rest areas are off-road designated locations provided for drivers and passengers to

take rest breaks and overcome fatigue. A major challenge to realizing the potential benefits of rest areas is to increase backing by those road users travelling long distances.

- a) Mini amenity centres or rest area with public toilets and kiosks shall be provided even at every 10km along by considering basic way-side amenities provided at hotels and petrol bunkers
- b) Modern amenity centres with toilet, refreshments, Wi-Fi facility etc at distance of not more than 25 km.
- c) Amenity centres should have parking facilities to heavy commercial vehicles.



Figure 10.14 Amenity centres sign

10.7 AVENUE PLANTATION AND LANDSCAPING

- 1) The area where footpaths are not essential, buffalo grass turfing may be considered between the edge of ROW line and end of paved shoulders to facilitate the limited pedestrian movement and smooth natural drainage.
- 2) Avenue plantation with Kanikkonna and/or Jackfruit trees at a spacing of 10 m c/c at select stretches of roads provided land is available or can be obtained at free of cost or can be acquired with reasonable cost.



Figure 10.15 Avenue plantation



Figure 10.16 Pre-cast concrete Tree gratings

Chapter – 11

TRAFFIC FURNITURE

11.1 ROAD SIGNS

The purpose of road signs is to promote road safety and efficiency by providing for the orderly movement of all road users on all roads in both urban and non-urban areas. Road signs notify road users of regulations and provide warning and guidance needed for safe, uniform and efficient operation.

To be effective, a road sign should meet five basic requirements:

- 1) Fulfil a need;
- 2) Command attention;
- 3) Convey a clear and simple meaning;
- 4) Command respect from road users; and
- 5) Give adequate time for response.

Road signs are classified under the following three heads:

- 1) Mandatory/Regulatory Signs
- 2) Cautionary/Warning Signs
- 3) Informatory/Guide Signs

11.1.1 MANDATORY/REGULATORY SIGNS

Mandatory signs specify that an instruction must be carried out. All Mandatory or regulatory Signs are circular in shape except octagonal red STOP sign and the triangular GIVEWAY or YIELD sign. They are with

- Prohibitory Regulation: Red circular ring and diagonal bars with black symbols or arrows or letters on white background.
- Operational Control: The red ring indicates prohibitory regulation, and the diagonal red bar prohibits the action or movement indicated by the black symbol.
- Compulsory Direction Control: Mandatory signs giving positive instructions are circular with a white symbol on a blue background.

11.1.1 "Stop" and "Give Way" signs (Right of way signs)



Stop



Give Way

11.1.2 "Prohibitory" signs



U-Turn Prohibited



One way



One way



Left Turn Prohibited



Right Turn Prohibited



Overtaking Prohibited



No Entry



Vehicles Prohibited In Both Directions



Priority to Vehicles from the Opposite Direction



Horn Prohibited



Pedestrians Prohibited



Trucks Prohibited



Buses Prohibited



Two Wheeler Prohibited



Cars Prohibited

11.1.3 "No Parking" and "No Stopping" signs



No parking



No Stopping



No Standing

11.1.4 "Speed Limit" and "Vehicle Control" signs



Axle Load Limit



Height Limit



Length Limit



Load Limit



Width Limit



Maximum Speed Limit

11.1.5 "Restriction Ends" sign



Restriction Ends

11.1.6 "Compulsory Direction Control" and other signs



Compulsory Ahead



Compulsory Ahead or
Right Turn



Compulsory Ahead or
Left Turn



Compulsory Turn Right



Compulsory Left Turn



Compulsory Turn Right
(In advance Junction)



Compulsory Left Turn
(In advance Junction)



Compulsory Keep Left

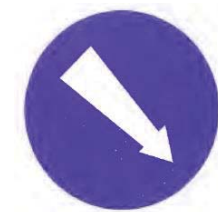

Compulsory Keep Right



Pass Either Side



Minimum Speed Limit



Compulsory Sound
Horn



Compulsory Cyclist and Pedestrian Route



Pedestrian Only



Bus Way/Bus Only

11.1.2 CAUTIONARY/WARNING SIGNS

Cautionary/Warning signs are triangular in shape with a red border and black symbol in the white background used to caution and alert the road users to potential danger or existence of certain hazardous conditions either on or adjacent to the roadway so that they take the desired action.



Left-Hand Curve

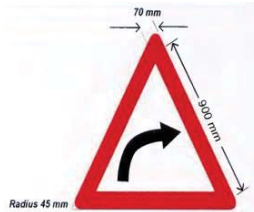

Right-Hand Curve



Right Hairpin Bend



Left Hairpin Bend



Right Reverse Bend



Left Reverse Bend



Series of Bends



270 Degree Loop



Side Road Right



Side Road Left



Y- Intersection



Y- Intersection



Major Road Ahead



Cross Road



Roundabout



Traffic Signals



Staggered Intersection



T- Intersection Major Road Ahead



Speed Breaker



Rumble Strip



Dangerous Dip



Merging Traffic Ahead (From Left)



Merging Traffic Ahead (From Right)



Narrow Road Ahead



Road Widens



Narrow Bridge Ahead



Steep Ascent



Airport



Reduced Carriageway



Reduced Carriageway
Right Lane(s) Reduced

Left Lane(s) Reduced



Start of Dual Carriageway



End of Dual Carriageway



Gap in Median



Pedestrian Crossing

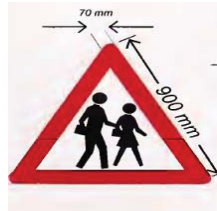

School Ahead



Built-up Area



Two Way Operation



Two-way Traffic on Cross



Lane Closed
(Two-Lane Carriageway)

Road Ahead Warning



Lane Closed
(Three Lane
Carriageway)



Lane Closed
(Four Lane
Carriageway)



Traffic Diversion on Dual
Carriageway



Men at Work



Danger Warning

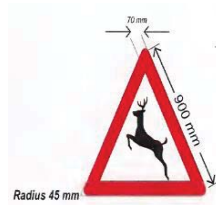

Wild Animals



Slippery Road



Overhead Cables



Playground Ahead



Quay Side or River Bank



Tunnel Ahead



Falling Rocks

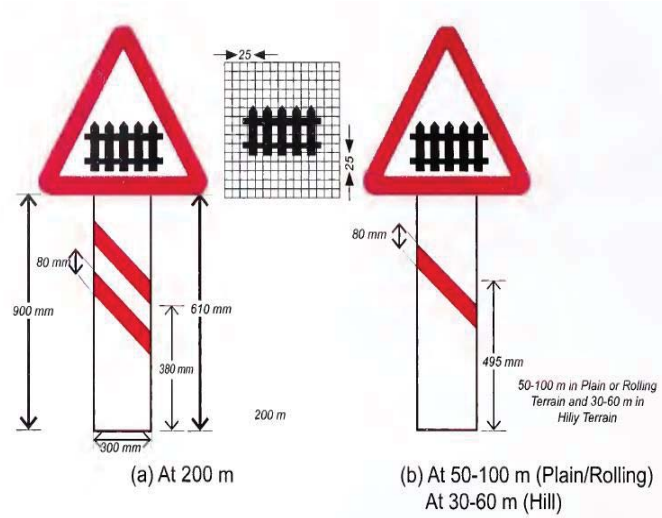

Guarded Railway Crossing

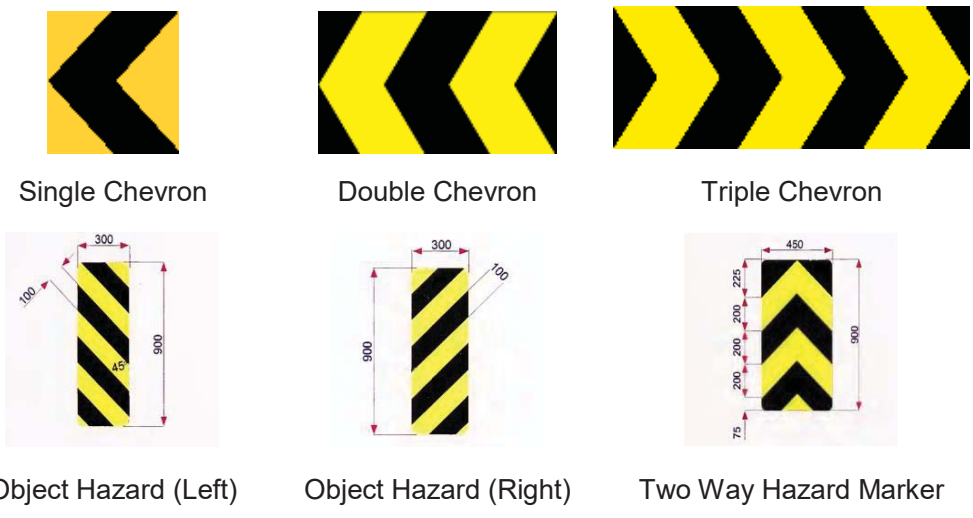

11.1.3 INFORMATORY/GUIDE SIGNS

These are used to give such information to road users which will help them along the route in most simple and direct manner. All Informatory signs and guiding signs for facilities are rectangular in shape.



Advance Direction Sign



Map type Advance Direction Sign



Map type Advance Direction Sign on Roundabout



Reassurance Sign



Place Identification Sign



Flag Type Direction Sign



Gantry Mounted Advance Direction Sign



Eating Place



Light Refreshment



Resting Place

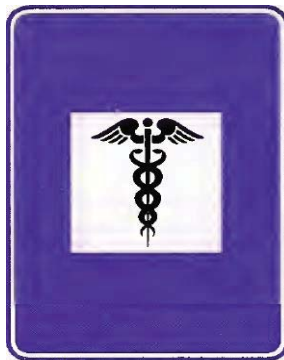

First Aid Post



Toilet



Filling Station (Fuel Pump)



Hospital



Public Telephone

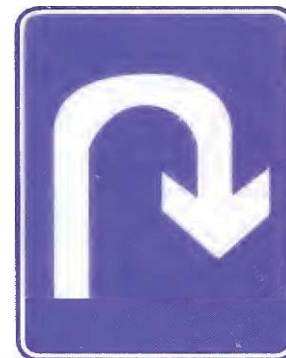

U-Turn Ahead



Pedestrian Subway



Police Station



Bus Stop

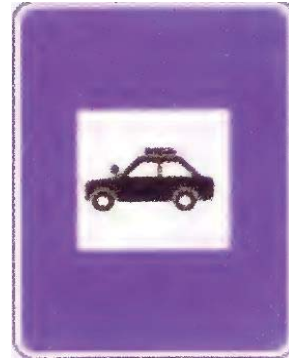

Repair Facility



Industrial Area



Taxi Stand



Autorickshaw Stand



Airport



Toll Road Ahead



Railway Station/Metro Station/Monorail Station

Parking

Parking for Persons with Disabilities



State Highway



National Highway



Expressway

11.2 ROAD MARKING

The essential purpose of road markings is to guide and control traffic on a highway. They supplement the function of traffic signs. The markings serve as a psychological barrier and signify the delineation of traffic path and its lateral clearance from traffic hazards for the safe movement of traffic. Hence, they are very important to ensure the safe, smooth and harmonious flow of traffic.

Commonly used materials for road markings are:

- Hot-applied thermoplastic compound
- Solvent-borne and waterborne road marking paints

Pavement markings are broadly classified into following seven categories based on the placement of markings regard to vehicular movement and also based on the function of the markings.

- i. Longitudinal Marking
- ii. Transverse Marking
- iii. Hazard Marking
- iv. Block Marking
- v. Arrow Marking
- vi. Facility Marking

11.2.1 LONGITUDINAL MARKINGS

Longitudinal markings are placed along the direction of traffic on the roadway surface, for the purpose of indicating to the driver, his proper position on the roadway.

11.2.1.1 Centre Line

The centre line should be used only on single carriageway roads to separate the opposite stream of traffic and to facilitate their movements. On unimportant roads

with less than 5.5 metres wide carriageway, centre lines are considered undesirable as these entail discomfort and hazard.

- For normal sections: 3 m Mark + 6 m Gap of 100 mm/150mm
- For warning Sections: 6 m Mark + 3 m Gap of 100 mm/150mm

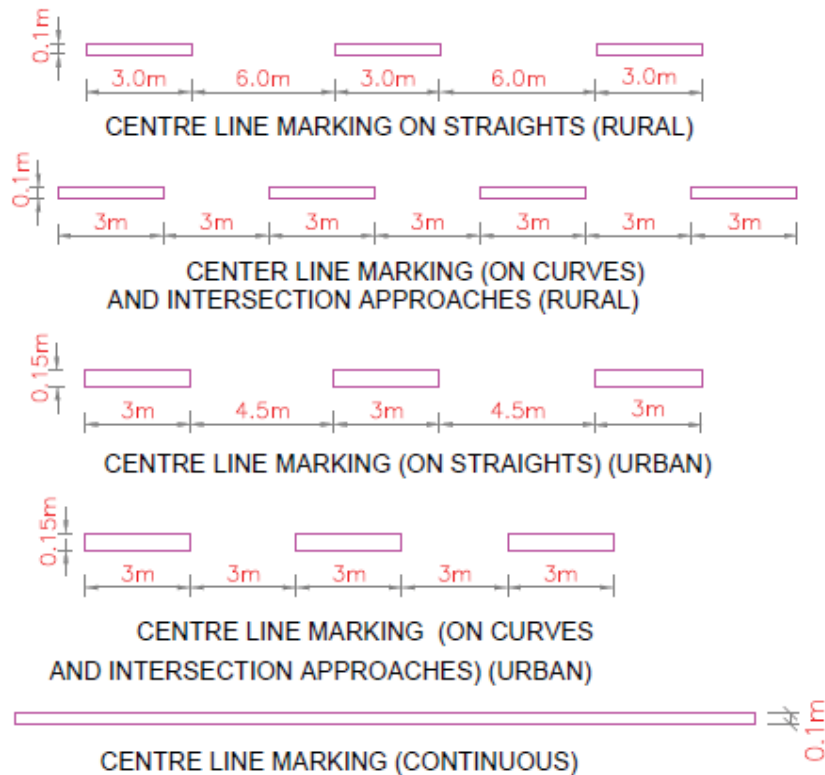

11.2.1.2 Traffic Lane Lines

The carriageway having two or more in one direction are divided into separate lane by traffic lane line marking for vehicles to move in proper lanes and to discourage the meandering tendency of the drivers.

- For normal sections (divided and undivided): 3 m Mark + 6 m Gap of 100 mm/150mm
- For warning Sections: 3 m Mark + 3 m Gap of 100 mm/150mm

11.2.1.3 No overtaking Lines

No overtaking zones shall be established on summit curves, horizontal curves and places with restricted sight distances or other hazardous conditions. No overtaking Lines shall be marked by a solid line either single or double along the centre or by ladder hatching.

11.2.1.4 Warning lines

These are marked on horizontal and vertical curves where the visibility is greater than prohibitory criteria specified for non-overtaking zones. These are always single, they should never be used as part of double line installation

11.2.1.5 Border or edge lines

These indicate carriageway edges of roads without kerbs to delineate the limits up to which driver can safely venture. It is a single continuous white line with 100 mm/150 mm width.

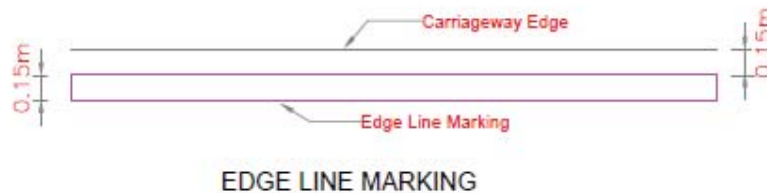

11.2.1.6 Bus lane markings

Reserved for buses, without physical separation should be provided with the white line as bus-lane markings. Base width of 2m is required for bus-lane.

11.2.2 TRANSVERSE MARKINGS

The marking provided across the carriageway for traffic control with broken lines, single & double continuous lines such as Stop marking and Give way marking are classified under this category. The transverse marking shall always be accompanied with a corresponding sign. The transverse line is 0.75 m long and 1.75 m apart for urban roads.

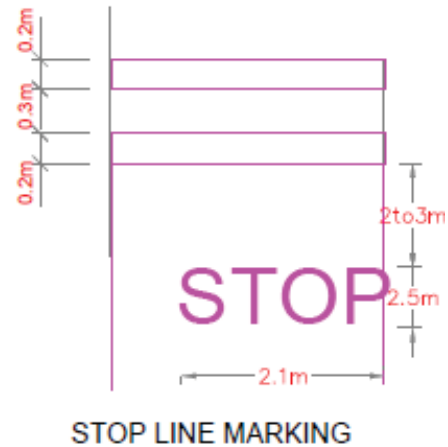

11.2.3 HAZARD MARKING

The pavement marking that facilitating traffic merging / diverging, prohibiting to cross-over and to deflect the traffic ahead of hazardous situations, generally done with like chevron and diagonal marking, hatch marking and prohibitory marking and such markings are classified under Hazard Marking. The hazard marking shall always be accompanied with an appropriate sign.

11.2.4 KERB MARKING

Kerbs located in the line of traffic flow shall be painted with alternative black and white stripes of 500mm wide.

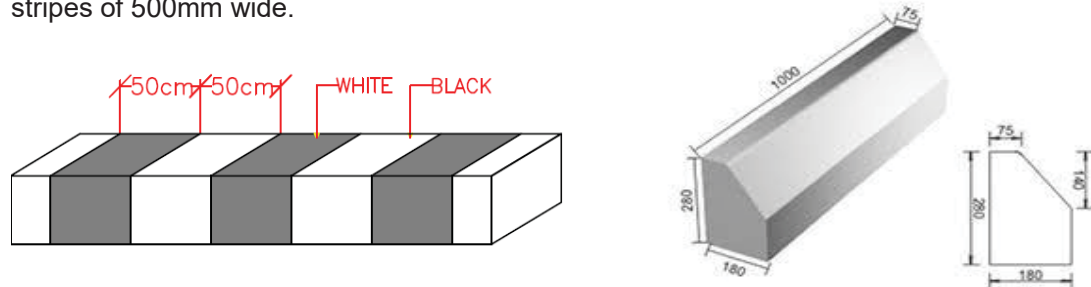

11.2.5 BLOCK MARKING

The zebra crossing for pedestrians, triangular marking for speed breakers and Give way symbol which is painted in blocks on carriageway are classified under Block Marking as per IRC:35.

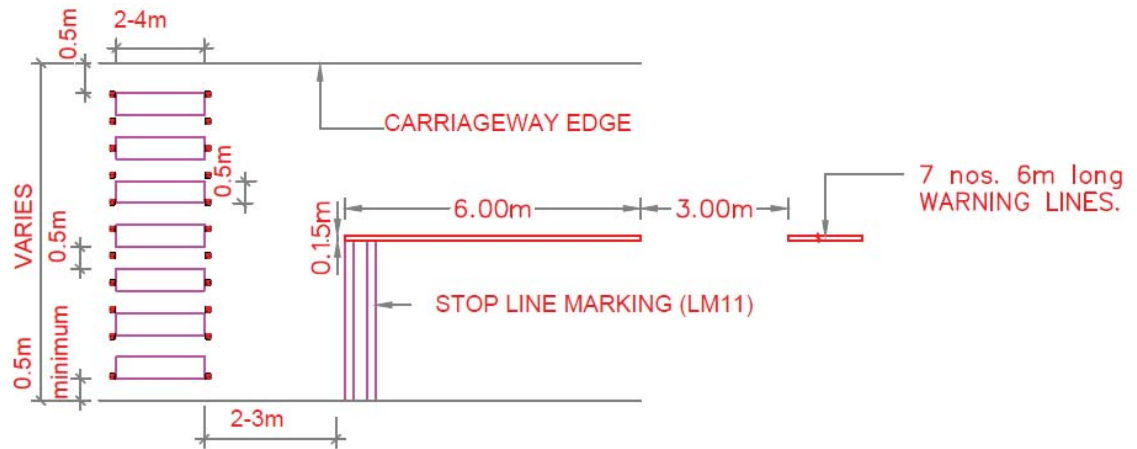
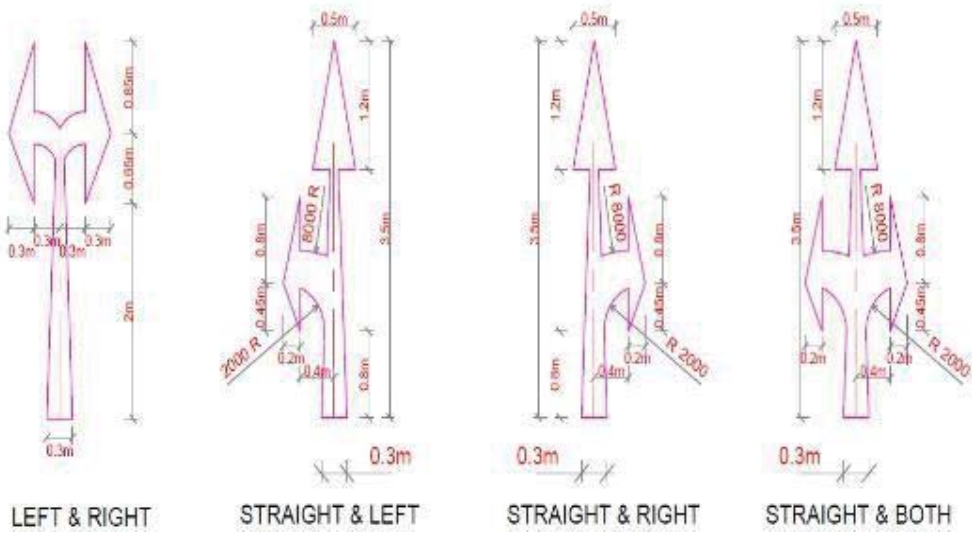
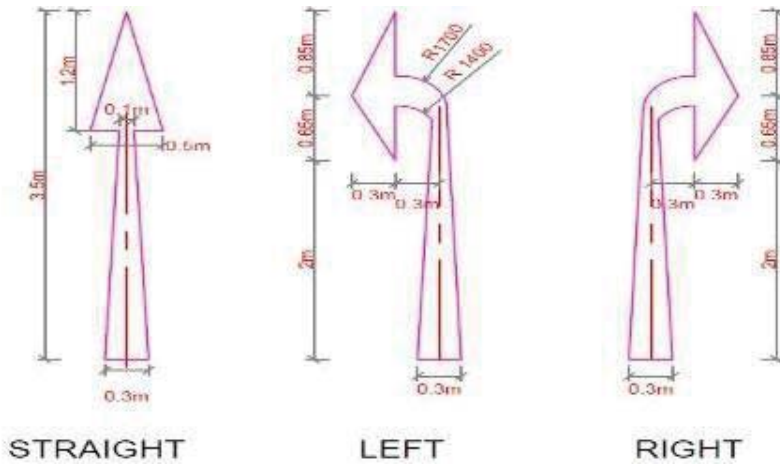

Figure 8 Pedestrian crossing marking

11.2.6 ARROW MARKING

The arrows painted on carriageway are meant to give direction for the driver to take mandatorily and are classified under Arrow Marking.



Arrow marking for route direction for design speed more than 50kmph

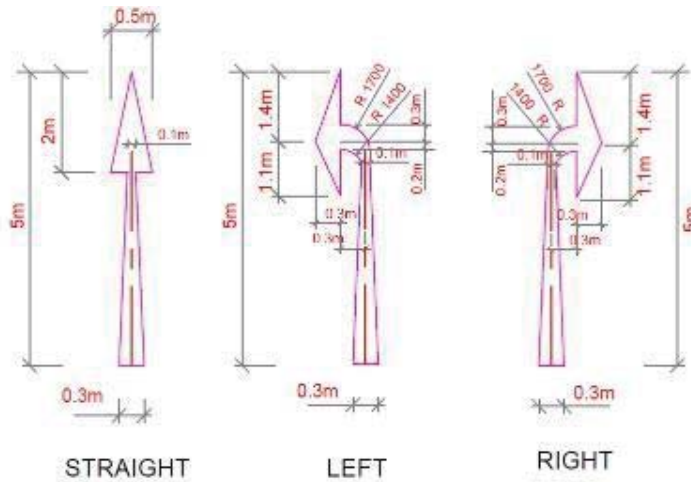

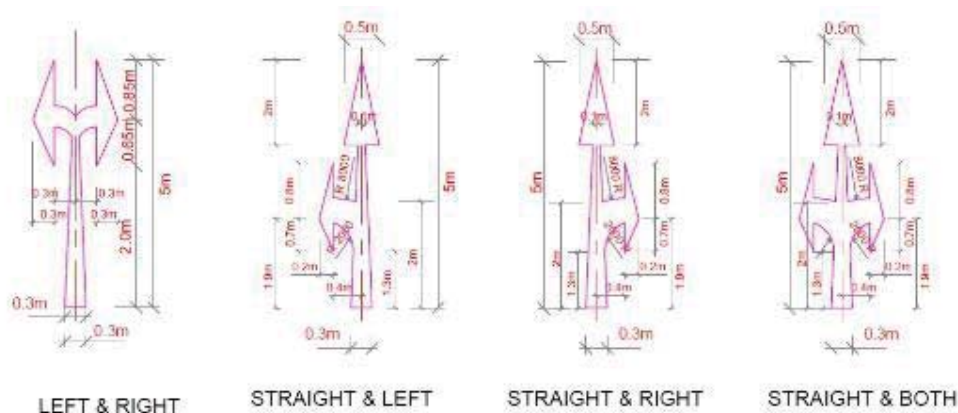

Arrow marking for route direction for a design speed of 50kmph or less

11.2.7 FACILITY MARKING

The marking for parking, the word messages for buses, cyclists and disabled ones are classified under Facility. Letters of length 1.25 m high in the direction of travel should be adopted for speeds up to 50 kmph speed, 2.5 m for 51-100 kmph and 5 m for speed greater than 100 kmph and expressways.

11.3 ROAD STUDS

Retro-reflective studs are used to supplement longitudinal/transverse reflectorized road markings, which would improve visibility in night time and adverse conditions. Road studs are also used across the carriageway to serve as speed arrester coupled with eschewing warning through the creation of the rumbling sensation to the user. The use of different colours of studs is as follows.

White: Indicate traffic lane line and centre of the carriageway.

Red: Indicate lines which should not be crossed and mainly to delineate the left hand edge of the running carriageway.

Yellow: Indicate lines which should not be crossed and mainly to delineate right-hand edge of the running carriageway.



Solar-type road stud



Median indication road stud and median opening indicating studs

Chapter – 12

JUNCTION IMPROVEMENT

The importance of the design of the junctions and intersections stems from the fact that the efficiency of operation, safety, speed, cost of operation and capacity are directly governed by the design. The main objective of intersection or junction design is to facilitate the convenience, comfort, and safety of people traversing the intersection while enhancing the efficient movement of the motor vehicle, buses, trucks, bicycles, and pedestrians and to reduce the number and severity of the potential conflicts between these stakeholders.



The basic principles of good intersection design are:

- i. Separate conflicts in space or time and minimize the number of conflict points reduce the risk of accidents.
- ii. Give priority to major traffic movements, through alignment, signing and traffic control.
- iii. Control the angle of conflict; crossing streams of traffic should intersect at a right angle or near right angle.
- iv. Define vehicle paths and ensure adequate sight distances
- v. Control approach speeds using alignment, lane width, traffic control or speed limits.
- vi. Minimise roadside hazards, Provide for all vehicular and non-vehicular traffic likely to use the intersection,
- vii. including goods vehicles, public service vehicles, pedestrians and other vulnerable road users.
- viii. Simplify the driving task, so that road users have to make only one decision at a time and minimise road user delay



Components of junction design

1) Traffic channels

Channelisation is the separation or regulation of conflicting traffic movements into definite paths of travel by the use of pavement markings or raised islands, to facilitate the safe and orderly movement of both vehicles and pedestrians.

2) Pedestrian island or refuge island

Pedestrian safety islands limit pedestrian exposure in the intersection. While safety islands may be used on both wide and narrow streets, they are generally applied at locations where speeds and volumes make crossings prohibitive, or where three or more lanes of traffic make pedestrians feel exposed or unsafe in the intersection

3) Pedestrian walk area – Provided in chapter 10.1

4) Hand rail- Provided details in chapter 13.1

5) Road markings- Provided in chapter 11.1

6) Chevron markings as per IRC:35-2015

7) Traffic signals

Traffic signal design and installation should be as per IRC:93.

Chapter – 13

ROAD SAFETY BARRIERS

The safety barriers are designated to redirect errant vehicles with a specified performance level and provide guidance for pedestrians or other road users. They are designed to redirect the vehicle and have a lower severity than the roadside hazard they protect. There are three main types of safety barrier (but within these types, there are different systems which have their own specific performance characteristics).



13.1 RAILINGS

Railings may be used in median, dividers and footpaths to prevent pedestrians to the un-manner crossing. Railing to be fixed with a strong concrete base and should be continuous.

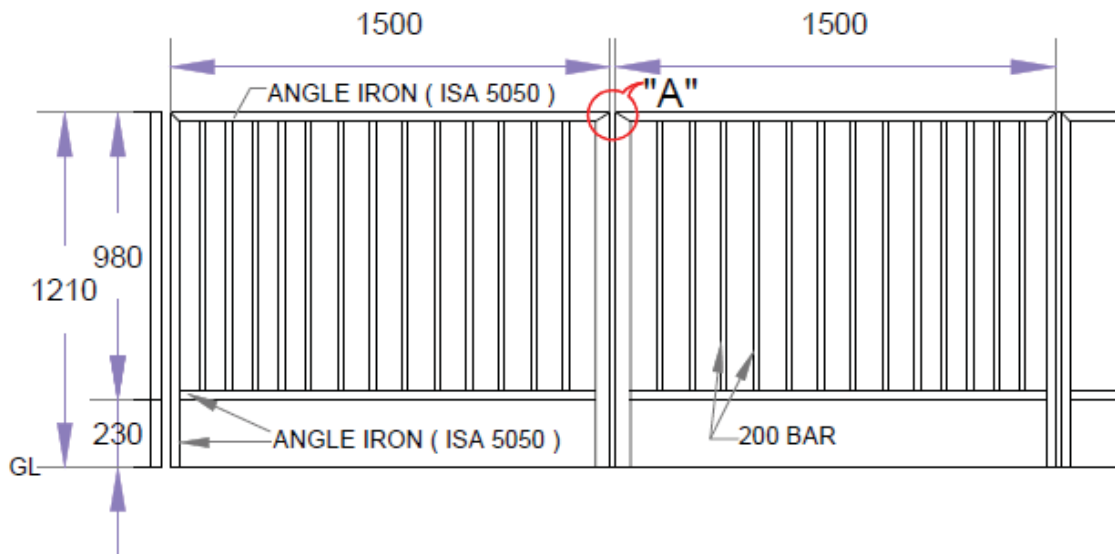

Typical layout of railing

Railing may be considered for footpaths in the vicinity of junctions to ensure that pedestrians can cross only at the designed crossing and also to prevent vehicles movement on the footpath.

13.2 RUMBLE STRIPS

These strips are raised, or grooved patterns mainly provided inside edge of paved shoulders on the unprotected roads. Roads rumble strips are provided to reduce run-off-road collisions.



Rumble strips (a) bitumen & (b) yellow line at inside side edge of paved shoulder

13.3 SAFETY BARRIERS

13.3.1 Flexible barriers are made from wire rope supported between frangible posts. Flexible barriers may be the best option for minimizing injuries to vehicle occupants, however, they may pose a risk to motorcyclists. These barriers deflect more than other barrier types and need to be repaired following impact to maintain their re-directive capability.



13.3.2 Semi-rigid barriers are usually made from steel beams or rails. These deflect less than flexible barriers and so they can be located closer to the hazard when space is limited. Depending on the impact these barriers may be able to redirect secondary impacts.

(i) W beam crash barrier

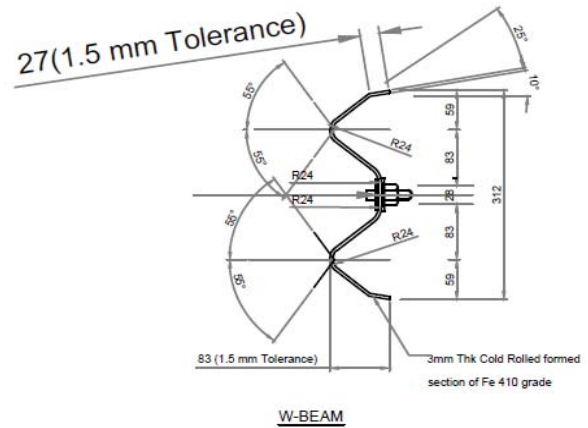

(ii) Roller type

Roller type barriers can also be provided where needed.

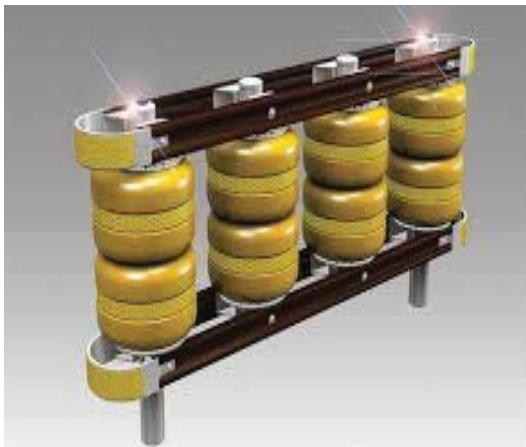

13.3.3 Rigid barriers are usually made of concrete and do not deflect. Rigid barriers should be used only where there is no room for deflection of a semi-rigid or flexible barrier. Rigid barriers are often utilized at high volume roadwork sites to protect road workers or other road users, particularly where another barrier type is awaiting repair. Currently (depending on their height and other details) these provide the highest level of containment of heavy vehicles. In most cases following an impact, these barriers require little or no maintenance.



13.4 GUARD POST

Guard stone or boundary stones shall be fixed at all angular points of the boundary. Where boundary is on a curve or the land is costly and likely to be encroached upon, there shall be planted closer, as necessary in each case.

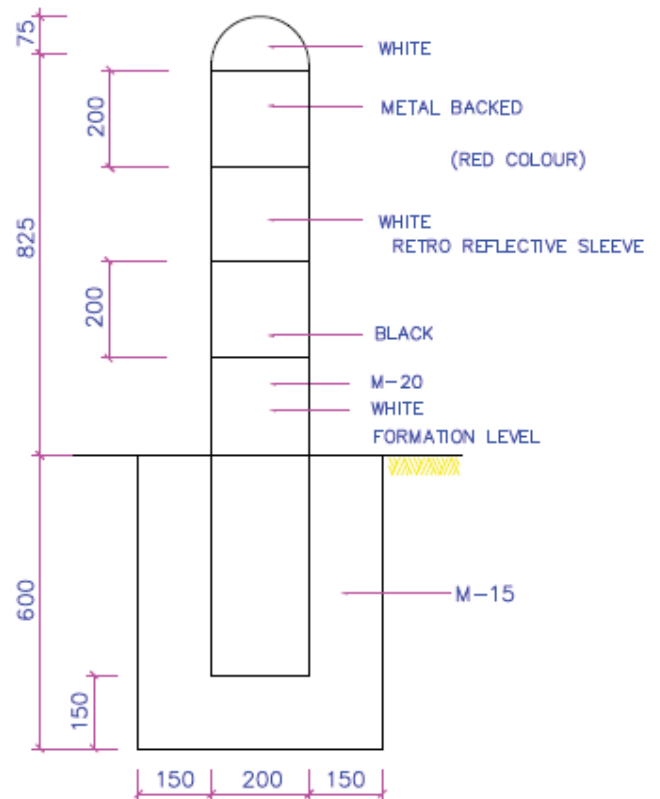

13.5 BOLLARDS

Bollards are entry restricting elements on streets whose purpose is to discourage vehicle from entering into pedestrian space or cycle tracks. Bollards are also used to demarcate and safeguard any space for pedestrians. Bollards should have reflective radian tape fitted on it to make it easily visible in the dark.

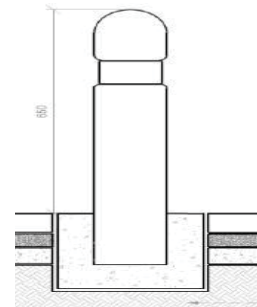

13.6 DELINEATORS

Delineators help guide pedestrians and motorists alike around construction areas or even accidents. Using a delineator is an effective way to safely redirect traffic away from potentially harmful situations.



Chapter – 14

ROAD SAFETY AUDITING

14.1 ROAD SAFETY AUDITING

Road safety audit shall mandatorily be conducted by a third party certified road safety auditor, as per IRC: SP- 88, for all roads developed under KIIFB funding, as per standard practices and all provisions shall mandatorily be included in the DPR and estimate. The road safety audit should be conducted during the construction and operational stages also.

A road safety audit is a term used internationally to describe an independent review of a future road project to identify anything that may affect the road's safety. The audit team considers the safety of all road users and qualitatively reports on road safety issues and opportunities to improve safety.

Specific aims of Safety Audit;

- i. To minimize the risk of accidents likely to occur/occurring on the project facility and to minimize their severity.
- ii. To minimize the risk of accidents likely to occur/occurring on adjacent roads i.e., to avoid creating accidents elsewhere on the network.
- iii. To recognize the importance of safety in highway design to meet the needs and perceptions of all types of road users; and to achieve a balance between the needs of different road user types where they may conflict with one another.
- iv. To reduce long-term costs of a project facility, bearing in mind that unsafe designs may be expensive or even impossible to correct at a later stage.
- v. To increase awareness about safe design practices among all those involved in the planning, design, construction, and maintenance of roads,

Typical Activities in Road Safety Auditing.

- i. Minimize the likelihood of crashes occurring through safety conscious planning and design
- ii. Identification of Black spots
- iii. Ensure that, if crashes occur, then the likelihood of injury is minimized (Such as provision of anti-skidding surface and safety barriers)
- iv. Ensuring that safety-related design criteria (eg. Critical sight distance) have been met.
- v. Managing risk, such that the risk of occurring major safety problem is less than the risk of minor safety problems occurring.

- vi. Reducing the whole life cycle cost of a design (unsatisfactory designs are expensive to correct after built.)
- vii. Minimize the risk of crashes occurring in the adjacent road network.

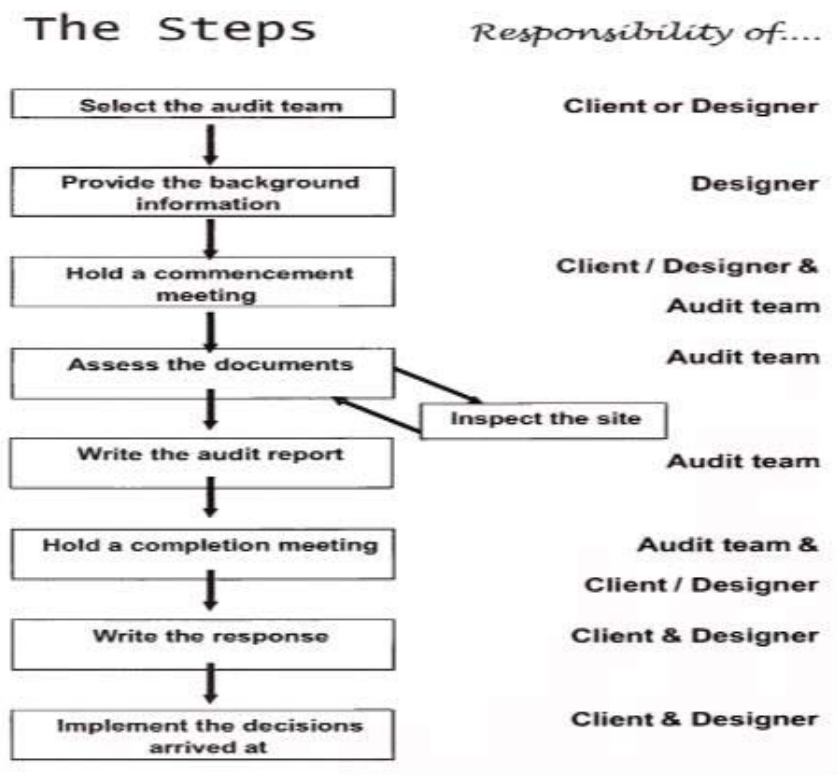

Figure: 3. Steps involved in road safety auditing as per IRC: SP-88

14.2 SOCIAL AUDITING

Social Audit is a monitoring process through which project information is collected, analyzed and shared publicly in a participatory fashion. Social audits may go beyond the oversight of project finances and procurements to examine all aspects of the project, including the level of access to information, accountability, public involvement, project outputs, and outcomes. Social audits are typically carried out by community volunteers (social audit teams/committees) and findings are presented at a public forum/hearing. Steps involved in the social auditing process

1. Define the scope of the audit
2. Information gathering and analysis
3. Public disclosure and evidence-based dialogue
4. Social audits institutionalized and repeated regularly

A social audit helps to reduce the gaps between vision and reality, between efficiency and viability. It values the voice of stakeholders, including marginalized/poor groups whose voices are rarely heard. Social auditing is taken up for the purpose of enhancing rehabilitation by local

governance, particularly for strengthening accountability and transparency in local bodies. Social auditing shall be conducted as per prevailing KPWD / CPWD / MoRTH / IRC rules before commencing of the project to evaluate the demand and requirement of the project.

14.3 ENVIRONMENTAL AUDITING

Environmental auditing is essentially an environmental management tool for measuring the effects of certain activities on the environment against set criteria or standards. These are used to help improve existing human activities, with the aim of reducing the adverse effects of these activities on the environment. Environmental auditing shall be conducted as per prevailing KPWD / CPWD / MoRTH / IRC rules before commencing of the project to evaluate the demand and requirement of the project. Environmental auditing must be conducted by considering,

1. Air Quality
 - recommended for dust control and mitigative measures
2. Noise control
 - recommended for an adopt noise reduction method of working and equipment's
3. Water Quality
 - recommended for mitigating measures to minimize water control during the construction phase.
4. Resource management (waste management, deforestation, etc.)
 - recommended for avoidance and minimization of waste generation
 - recommended for reuse of materials

 - recommended following relevant environmental protection and pollution laws.

Chapter – 15

SUSTAINABLE ROADS

Sustainable development is defined as the development that meets the needs of the present without compromising the ability of future generations to meet their own needs. This definition is focused on the concept of "needs" and the idea of limitations imposed by the state of technology and social organization on the environment's ability to meet present and future needs. In a shorter version of this, sustainability is often described as being made up of the three components of environmental, social, and economic needs.

"Sustainable" in the context of pavements refers to system characteristics that encompass a pavement's ability to:

1. Achieve the engineering goals for which it was constructed
2. Preserve and (ideally) restore surrounding ecosystems
3. Use financial, human, and environmental resources economically
4. Meet basic human needs such as health, safety, equity, employment, comfort, and happiness.

A "sustainable pavement" is, at present, an aspirational goal. That is, it is unlike any pavement system based on current knowledge and technology could satisfy all or even most of the characteristics in the previous sustainability definition. However, continued improvement with an emphasis on each of these characteristics leads to more sustainable pavements, and, ultimately, to pavements that actually meet the rather demanding standards of sustainability. Progress towards sustainability may at first mean reducing bad outcomes (e.g., less pollution, reduced extraction of non-renewable resources, less waste).

Improving sustainability can be achieved through the adoption of "sustainable best practices"; these are practices that work to either (1) go above and beyond required regulatory minimums or standard practice, or (2) show innovation in meeting these minimums and standards.

15.1 IMPORTANCE OF SUSTAINABILITY IN PAVEMENT ENGINEERING

The roadway system is one part of a transportation network that provides mobility and access to a range of users. The roadway network is not only important to overall economic vitality by providing for the movement of freight and commodities, but it also provides social benefits as well (e.g., access to schools, services, and work; leisure travel; and general mobility). Pavements are an integral part of this roadway network. Pavements provide a smooth and durable all-weather travelling surface that benefits a range of vehicles (cars, trucks, buses,

bicycles) and users (commuters, commercial motor carriers, delivery and service providers, local users, leisure travellers).

With regard to components, listed below are just a few examples of how pavements can impact sustainability:

- Environmental component: energy consumption; GHG emissions; noise; air quality; storm water treatment.
- Social component: safety (fatalities, injuries, property damage); smoothness; vehicle operating costs; GHG emissions; access, mobility; aesthetics.
- Economic: construction, maintenance, and rehabilitation costs; vehicle operating costs; crash costs.

In worldwide pavement engineering communities have adopted several technologies as a way of improving sustainability, such as the increased use of recycled materials in pavement structures, the incorporation of modified binders to increase pavement performance, and the development of rating systems to measure sustainability.

There are no universal characteristics or design features that describe sustainable pavement. Only a general sustainability framework for pavement can be defined, it is context sensitive in that each situation is unique, with specific needs depending on the location, climate, available materials, facility type, the required level of service, and so on, as well as on the overall goals of the organization.

15.2 WHAT ARE THE BENEFITS OF BEING MORE SUSTAINABLE?

Opportunities for improving the pavement sustainability exist throughout the pavement life cycle and have the potential to deliver tremendous economic, environmental, and social benefits. Listed below are just a few examples of the benefits of being more sustainable about the three pillars of sustainability.

Economic

- Reduced pavement life-cycle costs

Environmental

- Reduced energy use
- Reduced noise emissions
- Improved air quality
- Improved water quality

Social

- Improved safety
- Improved ride quality
- Resource conservation
- Reduced landfill space

REFERENCES:

IRC :9 - Traffic Census on Non-Urban Roads

IRC: 11 – Design & Layout of cycle Tracks

IRC: 23 - Vertical Curves for Highways;

IRC:34 – Recommendations for road construction in areas affected by water logging, flooding and/or salts infestation (first revision)

IRC: 35 - Code of Practice for Road Markings;

IRC: 36 - Recommended practice for the construction of earth embankments and sub-grade for road works;

IRC: 37- Guidelines for the Design of Flexible Pavements;

IRC: 38 - Guidelines for Design of Horizontal Curves for Highways and Design Tables;

IRC: 64- Guidelines for Capacity of Roads in Rural Areas;

IRC: 66–Recommended Practice for Sight Distance on Rural Highways;

IRC: 67–Code of Practice for Road Signs;

IRC: 72- Guidelines for the Design of Flexible Pavements for Low Volume Rural Roads;

IRC: 73- Geometric Design Standards for Rural (Non-Urban) Highways;

IRC: 79-Recommended practice for Road Delineators;

IRC: 80-Type Designs for Pick-up Bus Stops on Rural (i.e., Non-Urban) Highways;

IRC: 81-Guidelines for the strengthening of flexible road pavements using Benkelman Beam Deflection Technique;

IRC: 86 -Geometric design standards for urban roads in plains.

IRC: 93 - Guidelines on Design and Installation of Road Traffic Signals;

IRC: 103- Guidelines for Pedestrian Facilities;

IRC: 108 - Guidelines for Traffic Prediction on Rural Highways;

IRC: 115 - Guidelines for Structural Evaluation and Strengthening of Flexible Road Pavements Using Falling Weight Deflectometer (FWD) Technique;

IRC: 119 – Guidelines for Traffic safety barriers

IRC: SP-13- Guidelines for the design of small Bridges and Culverts;

IRC: SP-15 – State of the art: Landslide correction techniques.

IRC: SP-19 - Manual for Survey, Investigation and Preparation of Road Projects

IRC: SP-41- Guidelines on Design of At-Grade Intersections in Rural & Urban Areas;

IRC: SP-42 - Guidelines on Road Drainage;

IRC: SP-50 - Guidelines on Urban Drainage;

IRC: SP-59 - Guidelines for use Geotextile in road pavement and associated works;

IRC: SP-63 - Guidelines for the use of interlocking concrete block pavement;

IRC: SP:72- Guidelines for the Design of Flexible Pavements for Low-volume Rural Road

IRC: SP-73 – Manual of specification & standards for two laning of highways with paved shoulder

IRC: SP-88 - Manual on road safety auditing;

IRC: SP:89- Guidelines for soil and granular material, stabilization using cement lime& fly ash

IS: 2720 (Part 4) - Grain size analysis

IS: 2720 (Part 5) - Atterberg limits

IS: 2720 (Part 8) - Modified Proctor Test (OMC & MDD)

IS: 2720 (Part 16) - California Bearing Ratio



Section Officer